

OmegaFlex[®]

Manufacturer of Flexible Metal Hose and Braid Products



ISO 9001
QMI-SAI Global

ISO 10380 QUALIFIED



General Product & Engineering Design Catalog

November 2019

| | |
|-------------------------|---|
| The OmegaFlex Advantage | 1 |
| ISO 10380 Summary | 2 |
| Terminology | 3 |

PRODUCT SPECIFICATIONS

| | |
|---|----|
| Stainless Annular Hose | 5 |
| Stainless Tubular & Braided Braid | 8 |
| Stainless Abrasion Resistant Braid | 9 |
| Stainless High Pressure Hose | 10 |
| Stainless Helical Hose | 11 |
| Stainless Tubular Braid | 12 |
| Bronze Annular Hose | 13 |
| Bronze Tubular Braid | 14 |
| Monel Annular Hose | 15 |
| Monel Tubular Braid | 16 |
| Iconel Hose | 17 |
| Iconel Braid | 18 |
| Hastelloy | 19 |
| Hastelloy Braid | 20 |
| Stainless Hose (TPV) Extruded | 21 |
| Stainless Hose (LLDPE) Extruded | 22 |
| Stainless Hose Insulated (LLDPE) Extruded | 23 |

HOSE ASSEMBLIES

| | |
|--|----|
| Chlorine Transfer Hose | 24 |
| Cargo Transfer Hose | 24 |
| Formex Hose | 24 |
| Jacketed Hose | 25 |
| Oxygen Lance Hose | 25 |
| High Pressure Hose | 25 |
| Vibration Absorbers | 25 |
| Chlorine Hose Assembly | 26 |
| Chlorine Hose Assembly With Monel Stub Ends & Carbon Steel Flanges | 27 |

ENGINEERING & DESIGN

| | |
|--------------------------------|----|
| Terminology | 28 |
| Motion | 32 |
| Pressure | 36 |
| Flow Velocity | 36 |
| Media | 38 |
| Temperature | 38 |
| Testing | 38 |
| Cleaning | 38 |
| Temperature Correction Factors | 39 |
| Fittings | 40 |
| Installation Precautions | 41 |
| Service Life Factors | 42 |
| Corrugated Metal Hose | 44 |
| Hose Application Specifier | 45 |
| Limited Warranty | 46 |
| Disclaimer | 46 |



Call 1-800-355-1039

THE OMEGAFLEX ADVANTAGE



EXPERIENCE

Supplying quality engineered flexible metal hose products that meet demanding industrial applications requires dedication, experience and innovation. Since 1975, OmegaFlex has met these expectations by constantly developing superior manufacturing processes to produce corrugated flexible metal hose and braid products.

PHILOSOPHY

It is the policy of OmegaFlex, to design, fabricate, market and distribute products with consistently high quality that will reliably perform their intended function, resulting in the company's recognition as a quality leader in the industry.

The quality of our products is a direct reflection of the quality of our people, and is the primary reason for our success.

OmegaFlex, to be recognized as a world class manufacturer will:

- Provide our customers quality products through teamwork and continuous improvements
- Strive for zero defects in our products
- Create an environment that allows OmegaFlex continuous and prosperous growth
- Provide a positive working environment with progressive training
- Stress quality awareness and its benefits to our customers and employees
- Empower our employees to perform to the best of their abilities.

ADVANTAGE

mega Corrugation - No stress points when flexing thicker wall provides longer service life and increased pressure ratings. Meets ISO 10380 50K Cycle Test. Omegaflex Hose meets Industrial Oxygen Cleanliness. No additional cleaning required.

Omega Flex, Inc. 2006, 2007
OmegaFlex® is a registered
trademark of Omega Flex, Inc.

TECHNICAL

OmegaFlex's emphasis on engineering and quality has resulted in the largest expansion of our quality and engineering departments in company history. OmegaFlex, as a result of the refinement and discipline of our quality program, has been awarded registration as an ISO9001 manufacturer.

Our engineering department has established procedures for the complete qualification of products manufactured by OmegaFlex. As a result of our registration to ISO9001, all new products are subject to complete design review, validation and verification prior to product release. In compliance with our quality program, design and testing documentation is maintained on all existing and new products manufactured by OmegaFlex.

Material Test Reports, supplied to OmegaFlex by our vendors, provides complete raw material traceability and verification throughout our manufacturing process and shipping to our customers.

OmegaFlex's laboratory personnel and the equipment in our in-house metallurgical lab have also been expanded to include sectioning, mounting, polishing, etching and metallograph equipment for failure and grain size analysis. Instron tensile testing, hardness testing and alloy identification equipment round out one of the most complete in-house laboratories in the industry.

SERVICE

OmegaFlex is committed to serving our customers with the largest selection of sizes and materials in the corrugated metal hose industry. Whether we are designing specialty hose assemblies for OEM applications or supporting our large network of fabricating distributors, OmegaFlex has the dedication and resources to meet the needs of today's industrial requirements. Ultimate customer service, quality engineered products and on-time shipments are our goal.

Metal hose products manufactured by OmegaFlex are used extensively in factories such as steel mills, chemical and petrochemical plants, pulp and paper mills, power plants, water and wastewater facilities. They are also used for cryogenic applications and cargo/chlorine transfer lines. Engineering and maintenance departments specify OmegaFlex because of our ability to solve "problem" applications.

Call 1-800-355-1039

Omega Flex, Inc., 451 Creamery Way, Exton, PA 19341-2509 Tel:1-610-524-7272 FAX:1-610-524-6484

www.omegaflex.com

ISO 10380 SUMMARY

ISO

ISO or International Standards Organization was created to establish worldwide standards for industry. They are responsible for formulation of standards regarding quality assurance or specific products. The ISO 10380 standard was developed to help define the industry requirements for design, manufacture and testing of corrugated metal hose and hose assemblies. The following is a summary of the various sections covered in this standard.

MATERIALS

ISO 10380 specification lists the more popular materials used in the manufacture of corrugated metal hose, braid, ferrules and end fittings. Two of most common materials utilized for corrugated metal hose are austenitic stainless steel and copper based alloys. The specification is very clear that the material used in manufacturing the corrugated metal hose shall be selected on the basis of their suitability for forming or welding and for the application conditions under which they will operate. Materials other than those listed above may be selected by agreement between the manufacturer and the user.

CRITICAL DIMENSIONS

Details and requirements specified in this section include hose diameter, bend radii and overall length tolerances. It is common for manufacturers to list their nominal hose diameter in published literature. ISO 10380 lists the requirement that the actual hose inside diameter will be at least 98% of the nominal hose size.

The bend radius covered in the specification includes nominal static and nominal dynamic bend radius. Dynamic bend radius is used in cycle life fatigue testing. Overall length tolerances listed in the ISO 10380 are -1% to +3%.

DESIGN

Pressure

The specification lists the maximum permissible pressure ratings to be used in testing performed in accordance with ISO10380.

Elevated Temperatures

Pressure reduction for elevated temperature conditions is critical in applying the proper metal hose for an application. This specification provides for a method of determining the maximum service pressure for a metal hose assembly under these conditions.

Low Temperatures

The materials listed in the specification, with the exception of carbon steel, do not need to be derated in low temperature applications down to -392°F or -200°C. Carbon steel material used for end fittings may be used to a minimum temperature of -68°F or -20°C.

Cycle Life

Corrugated metal hose bend radius and minimum acceptable cycle life design requirements are outlined. Values and test criteria for meeting static and dynamic bend radii are also listed.

CONSTRUCTION

Hose

Manufacturing and corrugation designs are addressed by the ISO 10380 specification. Seamless or longitudinally welded tube may be corrugated into annular or helical corrugation designs. Details of methods for joining or segmenting metal hose are also listed.

Braid

ISO 10380 specifications are broad for the design of the braid.

Methods of Assembly

Many different methods of fitting attachment and unacceptable weld characteristics are outlined by the ISO10380 specification. The use of protective covers is also addressed.

TESTING

General Tests

Bend, fatigue and burst test requirements are defined by ISO 10380. OmegaFlex performs each of these tests when designing or qualifying our products. The fatigue test is widely recognized in the metal hose industry as a standard for cycle life testing. While ISO 10380 lists the average number of cycles of 50,000 at their specified pressure ratings, OmegaFlex performs testing at our published maximum working pressure.

Production Tests

Several types of non-destructive testing is addressed by the specification. These include pressure proof test by hydraulic pressure or pneumatic pressure and leakage test by pneumatic or vacuum testing. Cleaning and marking of metal hose assemblies is outlined.

TERMINOLOGY

METAL HOSE

Corrugated metal hose allows for the transfer of liquids or gases, usually at high pressure and high or cryogenic temperature, while remaining flexible.

Corrugation Design

Annular hose is formed from tubing into individual parallel corrugations. **Helical** hose is also formed from tubing but into a continuous spiral corrugation. Both designs allow for flexibility of the hose assembly under pressure. In addition, helical hose has unique self-draining properties.

Pitch

Corrugated metal hose is normally manufactured in **Standard Pitch** (Close Pitch). Each manufacturer specifies a standard number of corrugations per foot based on their desire to provide for acceptable flexibility while considering economic requirements.

Open Pitch hose is also available and has fewer corrugations per foot. This hose will not be as flexible as a Standard Pitch hose and will have a much lower flexing cycle life. Open Pitch hose is intended to be used in less severe applications where flexibility and cycle life are not an important requirement or as an effective method for dampening vibration.

Superflex allows OmegaFlex to achieve greater flexibility without thinning the wall of the hose by increasing the number of corrugations per foot. Superflex will normally have a higher flexing cycle life and can be used in more severe applications where ease of flexibility is important.

Wall Thickness

Each manufacturer designs a hose with criteria for the wall thickness that considers flexibility, cycle life and corrosion resistance. Increasing or decreasing the wall thickness has both advantages and disadvantages to the user.

BRAID

Metal wire braid on a hose assembly provides the hose assembly a higher pressure capability by acting as a restraint against hose elongation and acts to dampen vibration. A second layer of braid may be used to increase pressure ratings provided the test pressure is not exceeded.

Other design considerations may result in the use of a heavy braid to increase abrasion resistance characteristics.

Braid Coverage

Optimal braid coverage is engineered to contain the core under pressure and reduce the possibility of squirm. Properly designed braid coverage will balance pressure capability with flexing requirements. Minimization of braid wear on the crown of the corrugation is also provided by optimal braid coverage.

Tubular Braid

Tubular Braid is manufactured by grouping single wires and then braiding them into an intricate pattern that tightens when the braid is stretched. Such a group of wires is also known as a strand.

Construction of the braid is expressed as (number of carriers) x (number of wires in each group) x (wire diameter). An example would be 24 x 8 x .012 where 24 is the number of carriers on the braiding equipment, there are 8 wires in each strand of wires and the diameter of each wire is .012".

Braided Braid

Larger diameter hose assemblies require the strength of Braided Braid. Braided braid is manufactured the same as tubular braid except that wires in the strand are braided together prior to the manufacture of the braid.

Construction is expressed the same as tubular braid except the use of parentheses around the groups of wire and the wire diameter. An example would be 128 x (21 x .016) where 128 is the number of carriers, 21 is the number of wires in each group and .016" is the diameter of each wire in the braid.

TERMINOLOGY (continued)

HOSE ASSEMBLY

Braid Sleeve/Ferrule

The braid sleeve or ferrule is used to isolate the end of the corrugated hose and braid from flexure. The core and braid are welded to the braid sleeve or ferrule during fabrication of the hose assembly.

Properties of the hose and braid material are changed during welding. This area where the properties are changed is known as the "heat-affected zone." The heat-affected zone must be isolated or premature failure of the hose assembly can occur. Care should be taken to insure the braid sleeve or ferrule has a proper fit.

Cover/Armor

The cover or armor on a metal hose assembly is used to protect the braid from external abrasion or to diffuse the media inside the hose in case of rupture. Many different materials can be used including interlock casing, heat shrink covers, lay-flat or many types of heavy-duty elastomers. The use of covers that contain chlorides (such as PVC) should be avoided.

Reinforced Ends

Reinforced ends or re-ends are recommended on applications where sharp bends or extreme flexure occurs near the end of the hose. A short interlock casing or spring guard is generally used to restrict bending.

Liner

Applications where the media being transferred is abrasive or the velocity of the media is above recommended levels require the use of a Liner.

Material for the liner is usually an interlock hose and it is welded to each end of the hose. The liner will allow for a smooth flow while maintaining hose flexibility and will reduce the inside diameter. The bend radius of the interlock hose may limit the bend radius of the corrugated hose. A directional flow arrow is normally provided on the outside of the hose assembly.

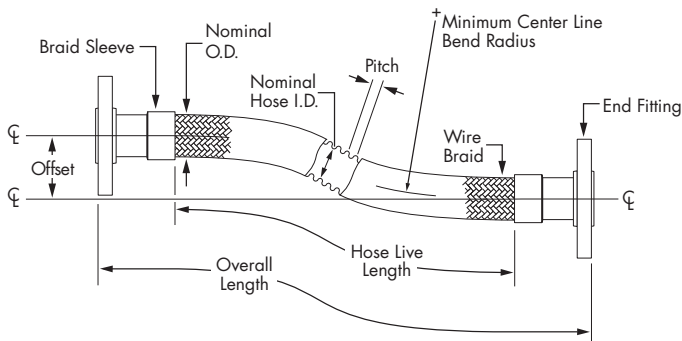

SPECIFICATION CHART HEADINGS

Hose Nominal Size

The nominal inside diameter of the hose.

Number of Braid Layers

The number of braid layers required to achieve the pressure ratings listed.

Nominal Outside Diameter

This column is usually used to determine the proper braid sleeve/ferrule or the cover dimensions.

Minimum Centerline Bend Radius

The hose may be bent to a radius not less than the indicated amount without permanent deformation. The type of flexing can be static or dynamic. Hose in a static bend is in a non-moving application. The dynamic application allows for random or intermittent flexing.

Pressure Ratings

Pressure ratings are shown in three categories:

Maximum Rated Working pressure is the maximum pressure the hose should be subjected to on a continuous basis.

Maximum Rated Test pressure is the maximum amount of pressure the hose can be subjected to during testing without possible deformation of the hose corrugations.

Nominal Rated Burst pressure is the pressure at which the hose assembly can be expected to fail.

Safety Factor of 4:1 is maintained by OmegaFlex on all published pressures.

Published pressures are shown in psig at 70°F. Reduction of pressure ratings should be used by the proper application of temperature correction factors. See page 38 for more information on temperature correction factors.

STAINLESS Hose

Series 300

ISO 10380 QUALIFIED

- Available in 304, 321, 316L stainless steel and other materials on request
- Pressure capability includes full vacuum to pressures shown below
- Temperature rating from cryogenic to 1500°F
- Consult Temperature Correction Table on page 39 for concurrent high temperature/high pressure applications
- Meets or exceeds ISO 10380 at maximum working pressure
- Hose corrugation designs include Standard Pitch, Open Pitch and Superflex. Contact OmegaFlex for specifications on Open Pitch and Superflex
- Shipped in mill lengths or Braided Hose-On-Reel for easy fabrication
- Standard braid material T304, other materials available upon request

Series 300 — RP Annular, Stainless Steel, Standard Pitch Hose (see page 6 for 2½"–16" sizes)

| Nominal Hose Size (in.) | Diameter Hose Size (DN) | Braid Layers | Nominal Outside Diameter | Nominal Inside Diameter | Minimum Centerline Bend Radius (in.) | | Pressure ratings at 70°F (PSIG) ^a | | | Weight per Foot (lb.) | Typical Mill Length (ft.) ^b |
|-------------------------|-------------------------|--------------|--------------------------|-------------------------|--------------------------------------|---------|--|-----------|---------------|-----------------------|--|
| | | | | | Static | Dynamic | Max. Working | Max. Test | Nominal Burst | | |
| ¼ ^c | 8 | 0 | 0.46 | 0.32 | 4 | 6 | 140 | 210 | — | 0.09 | 30–100 |
| | | 1 | 0.51 | | | | 2375 | 3563 | 9500 | 0.18 | |
| | | 2 | 0.56 | | | | 3125 | 4688 | 12500 | 0.27 | |
| ⅜ | 10 | 0 | 0.61 | 0.42 | 2 | 4 | 100 | 150 | — | 0.12 | 30–100 |
| | | 1 | 0.67 | | | | 1650 | 2475 | 6600 | 0.23 | |
| | | 2 | 0.73 | | | | 2200 | 3300 | 8800 | 0.35 | |
| ½ | 15 | 0 | 0.76 | 0.55 | 3 | 5 | 75 | 113 | — | 0.16 | 30–100 |
| | | 1 | 0.81 | | | | 1100 | 1650 | 4400 | 0.26 | |
| | | 2 | 0.87 | | | | 1625 | 2438 | 6500 | 0.37 | |
| ¾ | 20 | 0 | 1.05 | 0.81 | 4 | 6 | 50 | 75 | — | 0.26 | 30–100 |
| | | 1 | 1.10 | | | | 800 | 1200 | 3200 | 0.43 | |
| | | 2 | 1.16 | | | | 1250 | 1875 | 5000 | 0.62 | |
| 1 | 25 | 0 | 1.34 | 1.03 | 4.5 | 7 | 50 | 75 | — | 0.36 | 30–100 |
| | | 1 | 1.42 | | | | 750 | 1125 | 3000 | 0.62 | |
| | | 2 | 1.50 | | | | 1000 | 1500 | 4000 | 0.91 | |
| 1¼ | 32 | 0 | 1.64 | 1.30 | 4 | 11 | 25 | 37.5 | — | 0.45 | 30–100 |
| | | 1 | 1.72 | | | | 725 | 1088 | 2900 | 0.82 | |
| | | 2 | 1.80 | | | | 1100 | 1650 | 4400 | 1.23 | |
| 1½ | 40 | 0 | 1.89 | 1.53 | 4.5 | 12 | 20 | 30 | — | 0.48 | 30–100 |
| | | 1 | 1.95 | | | | 565 | 850 | 2260 | 0.82 | |
| | | 2 | 2.02 | | | | 887 | 1330 | 3550 | 1.23 | |
| 2 | 50 | 0 | 2.47 | 2.05 | 5 | 13 | 16 | 24 | — | 0.70 | 30–100 |
| | | 1 | 2.58 | | | | 500 | 750 | 2000 | 1.38 | |
| | | 2 | 2.69 | | | | 750 | 1050 | 3000 | 2.14 | |

a. OmegaFlex hose and corresponding braid must be used in combination to achieve pressure ratings.

b. Consult factory for longer lengths.

c. ¼" meets ISO 10380 cycle life requirements at OmegaFlex specified bend radius.

Hose-On-Reel

- Braided Hose-On-Reel is segmented into a continuous length to reduce scrap
- Convenient handling, storage and inventory control
- Reduces shelf space
- Also available in double braid construction

Note: See page 6 for specifying part numbers for Series 300.

Series 300 Braided Annular Hose-On-Reel, Single Braid^a

| Nominal Hose Size (in.) | Diameter Hose Size (DN) | Reel Quantity (ft.) | Reel Flange (in.) | Reel Width (in.) | Weight per Reel (lb.) |
|-------------------------|-------------------------|---------------------|-------------------|------------------|-----------------------|
| ¼ | 8 | 400 | 24 | 13 | 74 |
| ⅜ | 10 | 400 | 24 | 13 | 102 |
| ½ | 15 | 400 | 24 | 13 | 112 |
| ¾ | 20 | 300 | 28 | 15 | 128 |
| 1 | 25 | 200 | 28 | 15 | 178 |
| 1¼ | 32 | 300 | 45 | 19 | 263 |
| 1½ | 40 | 300 | 45 | 19 | 300 |
| 2 | 50 | 180 | 45 | 19 | 280 |
| 3 | 80 | 200 | 60 | 30 | 540 |
| 4 | 100 | 100 | 60 | 30 | 375 |

a. Use chart above for single braided hose specifications.

Omega Flex, Inc.,

451 Creamery Way, Exton, PA 19341-2509 Tel:1-610-524-7272 FAX:1-610-524-6484 www.omegaflex.com

Call 1-800-355-1039



STAINLESS Hose

Series 300

Series 300 — Annular, Stainless Steel, Standard Pitch Hose (see page 5 for ¼"–2" sizes)

| Nominal Hose Size (in.) | Diameter Hose Size (DN) | Braid Layers/Type | Nominal Outside Diameter | Nominal Inside Diameter | Minimum Centerline Bend Radius (in.) | | Pressure ratings at 70°F (PSIG) ^b | | | Weight per Foot (lb.) | Typical Mill Length (ft.) ^c |
|-------------------------|-------------------------|-------------------|--------------------------|-------------------------|--------------------------------------|---------|--|-----------|---------------|-----------------------|--|
| | | | | | Static | Dynamic | Max. Working | Max. Test | Nominal Burst | | |
| 2½ | 65 | 0 | 3.33 | 2.61 | 5 | 13 | 12 | 18 | — | 1.28 | 7–20 |
| | | 1 | 3.45 | | | | 400 | 600 | 1600 | 2.09 | |
| | | 2 | 3.57 | | | | 600 | 900 | 2400 | 2.98 | |
| 3 | 80 | 0 | 3.89 | 3.10 | 7.5 | 16 | 8 | 12 | — | 1.53 | 7–20 |
| | | 1 | 4.01 | | | | 288 | 431 | 1150 | 2.39 | |
| | | 2 | 4.13 | | | | 431 | 647 | 1725 | 3.35 | |
| 3½ | 90 | 0 | 4.36 | 3.50 | 8 | 17 | 7.5 | 11 | — | 1.65 | 7–20 |
| | | 1 | 4.45 | | | | 285 | 428 | 1140 | 2.80 | |
| | | 2 | 4.53 | | | | 400 | 600 | 1600 | 4.08 | |
| 4 | 100 | 0 | 4.83 | 3.98 | 10 | 20 | 5 | 7.5 | — | 1.95 | 7–20 |
| | | 1 | 5.03 | | | | 250 | 375 | 1000 | 3.14 | |
| | | 2 | 5.23 | | | | 375 | 563 | 1500 | 4.46 | |
| 5 | 125 | 0 | 5.94 | 5.03 | 12 | 24 | 3.5 | 5.3 | — | 2.76 | 7–20 |
| | | 1 | 6.10 | | | | 200 | 300 | 800 | 4.08 | |
| | | 2 | 6.14 | | | | 245 | 367 | 980 | 5.53 | |
| | | 1 BB | 6.22 | | | | 245 | 367 | 980 | 5.07 | |
| 6 | 150 | 0 | 6.99 | 6.03 | 15 | 30 | 3 | 4.5 | — | 3.34 | 7–20 |
| | | 1 | 7.15 | | | | 220 | 330 | 880 | 4.79 | |
| | | 2 | 7.35 | | | | 300 | 450 | 1200 | 6.39 | |
| | | 1 BB | 7.20 | | | | 275 | 413 | 1100 | 6.04 | |
| | | 2 BB | 7.50 | | | | 350 | 525 | 1400 | 8.79 | |
| 8 | 200 | 0 | 9.11 | 7.96 | 20 | 40 | 2.7 | 4.1 | — | 5.32 | 5–12 |
| | | 1 BB | 9.44 | | | | 215 | 323 | 860 | 8.73 | |
| | | 2 BB | 9.80 | | | | 275 | 413 | 1100 | 12.14 | |
| 10 | 250 | 0 | 11.19 | 9.85 | 25 | 50 | 2.2 | 3.3 | — | 8.71 | 5–12 |
| | | 1 BB | 11.49 | | | | 200 | 350 | 800 | 12.65 | |
| | | 2 BB | 11.88 | | | | 270 | 405 | 1080 | 16.59 | |
| 12 | 300 | 0 | 13.22 | 11.83 | 30 | 60 | 1.8 | 2.7 | — | 11.58 | 5–12 |
| | | 1 BB | 13.51 | | | | 160 | 240 | 640 | 17.53 | |
| | | 2 BB | 13.80 | | | | 220 | 330 | 880 | 23.48 | |
| 14 | 350 | 0 | 15.42 | 14.03 | 35 | 70 | 2.5 | 4.0 | — | 16.75 | 5–12 |
| | | 1 BB | 15.67 | | | | 150 | 225 | 600 | 23.00 | |
| | | 2 BB | 15.93 | | | | 190 | 285 | 760 | 29.25 | |
| 16 | 400 | 0 | 17.06 | 16.03 | 40 | 80 | 2.0 | 3.0 | — | 18.00 | 5–12 |
| | | 1 BB | 17.31 | | | | 110 | 165 | 440 | 24.50 | |
| | | 2 BB | 17.57 | | | | 170 | 255 | 680 | 21.00 | |

a. Standard braid constructions are shown without a type designation.

See pages 8 and 9 for detailed braid specifications. The "BB" designation indicates braided braid.

b. OmegaFlex hose and corresponding braid must be used in combination to achieve pressure ratings.

c. Consult factory for longer lengths.

Specifying Part Numbers for Series 300

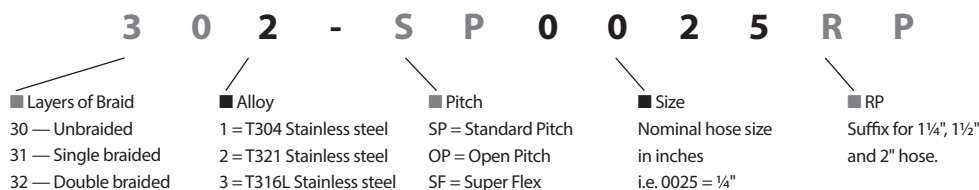

Omega Flex, Inc.,

451 Creamery Way, Exton, PA 19341-2509 Tel:1-610-524-7272 FAX:1-610-524-6484 www.omegaflex.com

Call 1-800-355-1039



STAINLESS Hose

Series 300

Formex (FX)

- Available in 321 and 316L stainless steel
- Pressure capability includes full vacuum to pressures shown below
- Temperature rating from cryogenic to 1500°F
- Consult Temperature Correction Table on page 39 for concurrent high temperature/high pressure applications
- Hose corrugation designs include Standard Pitch, Open Pitch and Superflex. Contact OmegaFlex for specifications on Open Pitch and Superflex
- Shipped in mill lengths or Braided Hose-On-Reel for easy fabrication
- Standard braid material T304, other materials available upon request

Series 300 Formex — RP Annular, Stainless Steel, Standard Pitch Hose

| Nominal Hose Size (in.) | Diameter Hose Size (DN) | Braid Layers/Type | Nominal Outside Diameter | Nominal Inside Diameter | Minimum Centerline Bend Radius (in.) | | Pressure ratings at 70°F (PSIG) ^a | | | Weight per Foot (lb.) | Typical Mill Length (ft.) ^c |
|-------------------------|-------------------------|-------------------|--------------------------|-------------------------|--------------------------------------|---------|--|-----------|---------------|-----------------------|--|
| | | | | | Static | Dynamic | Max. Working | Max. Test | Nominal Burst | | |
| | | | | | | | | | | | |
| ¼ | 8 | 0 | 0.51 | .32 | 4 | 6 | 98 | 147 | — | 0.09 | 30–100 |
| | | 1 | 0.51 | | | | 1663 | 2494 | 6650 | 0.18 | |
| | | 2 | 0.56 | | | | 2188 | 3282 | 8750 | 0.27 | |
| ¾ | 10 | 0 | 0.61 | .42 | 2 | 4 | 70 | 105 | — | 0.12 | 30–100 |
| | | 1 | 0.67 | | | | 1155 | 1733 | 4620 | 0.23 | |
| | | 2 | 0.73 | | | | 1540 | 2310 | 6160 | 0.35 | |
| ½ | 15 | 0 | 0.76 | .55 | 3 | 5 | 53 | 79 | — | 0.16 | 30–100 |
| | | 1 | 0.81 | | | | 770 | 1155 | 3080 | 0.26 | |
| | | 2 | 0.87 | | | | 1138 | 1707 | 4550 | 0.37 | |
| ¼ | 20 | 0 | 1.05 | .81 | 4 | 6 | 35 | 53 | — | 0.26 | 30–100 |
| | | 1 | 1.10 | | | | 560 | 840 | 2240 | 0.43 | |
| | | 2 | 1.16 | | | | 875 | 1313 | 3500 | 0.62 | |
| 1 | 25 | 0 | 1.34 | 1.03 | 4.5 | 7 | 35 | 53 | — | 0.36 | 30–100 |
| | | 1 | 1.42 | | | | 525 | 788 | 2100 | 0.62 | |
| | | 2 | 1.50 | | | | 700 | 1050 | 2800 | 0.91 | |
| 1¼ | 32 | 0 | 1.64 | 1.30 | 4 | 11 | 18 | 26 | — | 0.45 | 30–100 |
| | | 1 | 1.72 | | | | 508 | 762 | 2030 | 0.82 | |
| | | 2 | 1.80 | | | | 770 | 1155 | 3080 | 1.23 | |
| 1½ | 40 | 0 | 1.89 | 1.53 | 4.5 | 12 | 14 | 21 | — | 0.48 | 30–100 |
| | | 1 | 1.95 | | | | 396 | 595 | 1582 | 0.82 | |
| | | 2 | 2.02 | | | | 621 | 931 | 2483.6 | 1.23 | |
| 2 | 50 | 0 | 2.47 | 2.05 | 5 | 13 | 11 | 17 | — | 0.70 | 30–100 |
| | | 1 | 2.58 | | | | 350 | 525 | 1400 | 1.38 | |
| | | 2 | 2.69 | | | | 525 | 735 | 2100 | 2.14 | |

a. OmegaFlex hose and corresponding braid must be used in combination to achieve pressure ratings.

b. Consult factory for longer lengths.

Series 100 Braided Annular Hose-On-Reel, Single Braid^a

| Nominal Hose Size (in.) | Diameter Hose Size (DN) | Reel Quantity (ft.) | Reel Flange (in.) | Reel Width (in.) | Weight per Reel (lb.) |
|-------------------------|-------------------------|---------------------|-------------------|------------------|-----------------------|
| ¼ | 8 | 400 | 24 | 13 | 74 |
| ¾ | 10 | 400 | 24 | 13 | 102 |
| ½ | 15 | 400 | 24 | 13 | 112 |
| ¾ | 20 | 300 | 28 | 15 | 128 |
| 1 | 25 | 200 | 28 | 15 | 178 |
| 1¼ | 32 | 300 | 45 | 19 | 263 |
| 1½ | 40 | 300 | 45 | 19 | 300 |
| 2 | 50 | 180 | 45 | 19 | 280 |
| 3 | 80 | 200 | 60 | 30 | 540 |
| 4 | 100 | 100 | 60 | 30 | 375 |

a. Use chart above for single braided hose specifications.

Hose-On-Reel

- Braided Hose-On-Reel is segmented into a continuous length to reduce scrap
- Convenient handling, storage and inventory control
- Reduces shelf space
- Also available in double braid construction
- Specifying part numbers for Series 300.
- Add (FX) to end of standard part number
- 30X-SP0XXX-FX

Omega Flex, Inc.,

451 Creamery Way, Exton, PA 19341-2509 Tel:1-610-524-7272 FAX:1-610-524-6484 www.omegaflex.com

Call 1-800-355-1039



STAINLESS Braid

Tubular & Braided

- Materials available include 304, 321 and 316 stainless steel
- Wide range of constructions including 24, 36, 48, 72, 96 and 128 carrier designs
- Clean and oil-free
- Soft texture allows for easy trimming and quicker hose assembly fabrication
- Long mill lengths for less waste
- Engineered for optimal hose coverage
- Manufactured on OmegaFlex hose mandrels to ensure proper braid angle
- Custom braiding to customer specifications is available in 304, 321 and 316L stainless steel, bronze, monel, exotic alloys and synthetic materials

Tubular Braid for Series 300 Hose — Stainless Steel T304, T321 and T316

| Nominal Hose Size (in.) | Diameter Hose Size (DN) | Braid Construction | Braid I.D. (in.) | Braid Coverage (%) | Max. Working Pressure at 70°F (PSIG) ^b | Weight Per Foot (lb.) | Typical Mill Length (ft.) ^c |
|-------------------------|-------------------------|--------------------|------------------|--------------------|---|-----------------------|--|
| ¼ | 8 | 24 x 6 x .012 | 0.46 | 90 | 2375 | 0.065 | 30-100 |
| ⅜ | 10 | 24 x 8 x .012 | 0.61 | 94 | 1650 | 0.098 | 30-100 |
| ½ | 15 | 24 x 8 x .012 | 0.76 | 86 | 1100 | 0.101 | 30-100 |
| ¾ | 20 | 36 x 8 x .012 | 1.05 | 90 | 800 | 0.143 | 30-100 |
| 1 | 25 | 36 x 8 x .016 | 1.34 | 88 | 750 | 0.268 | 30-100 |
| 1¼ | 32 | 48 x 8 x .016 | 1.64 | 97 | 725 | 0.375 | 30-60 |
| 1½ | 40 | 48 x 8 x .016 | 1.89 | 96 | 565 | 0.377 | 30-60 |
| 2 | 50 | 48 x 8 x .020 | 2.47 | 96 | 500 | 0.680 | 30-60 |
| 2½ | 65 | 72 x 8 x .020 | 3.33 | 90 | 400 | 0.710 | 30-60 |
| 3 | 80 | 72 x 8 x .020 | 3.89 | 86 | 288 | 0.760 | 30-60 |
| 3½ | 90 | 72 x 10 x .020 | 4.36 | 86 | 285 | 1.150 | 30-50 |
| 4 | 100 | 72 x 10 x .020 | 4.83 | 84 | 250 | 1.130 | 30-50 |
| 5 | 125 | 96 x 8 x .025 | 5.94 | 87 | 200 | 1.320 | 50-100 |
| 6 | 150 | 96 x 8 x .025 | 6.99 | 82 | 175 | 1.470 | 50-100 |

a. Standard braid constructions are shown without a type designation.

b. Maximum working pressure shown is calculated for OmegaFlex annular hose and corresponding single layer braid. See Series 300 annular hose specifications for additional information. Performance may be reduced if braid is not used on OmegaFlex hose.

c. Consult factory for longer lengths.

Braided Braid for Series 300 Hose — Stainless Steel T304

| Nominal Hose Size (in.) | Diameter Hose Size (DN) | Braid Construction | Braid I.D. (in.) | Braid Coverage (%) | Max. Working Pressure at 70°F (PSIG) ^b | Weight Per Foot (lb.) | Typical Mill Length (ft.) ^c |
|-------------------------|-------------------------|--------------------|------------------|--------------------|---|-----------------------|--|
| 5 | 125 | 96 x (13 x .025) | 5.94 | 84 | 245 | 2.31 | 50-100 |
| 6 | 150 | 96 x (13 x .025) | 6.99 | 96 | 275 | 2.75 | 50-100 |
| 8 | 200 | 96 x (17 x .025) | 9.11 | 87 | 215 | 3.41 | 50-100 |
| 10 | 250 | 96 x (29 x .025) | 11.19 | 93 | 200 | 3.94 | 50-100 |
| 12 | 300 | 96 x (29 x .025) | 13.22 | 91 | 160 | 5.95 | 50-100 |
| 14 | 350 | 96 x (29 x .025) | 15.40 | 80 | 150 | 6.25 | 10-30 |
| 16 | 400 | 96 x (29 x .025) | 17.06 | 74 | 110 | 6.5 | 10-30 |

a. Standard braid constructions are shown without a type designation.

b. Maximum working pressure shown is calculated for OmegaFlex annular hose and corresponding single layer braid. See Series 300 annular hose specifications for additional information. Performance may be reduced if braid is not used on OmegaFlex hose.

c. Consult factory for longer lengths.

Note: To specify part numbers for braid products see page 9.

Omega Flex, Inc.,

451 Creamery Way, Exton, PA 19341-2509 Tel:1-610-524-7272 FAX:1-610-524-6484 www.omegaflex.com

Call 1-800-355-1039



STAINLESS Braid

Abrasion Resistant

- Materials available include T304 stainless steel
- Wide range of constructions including 24, 36, 48 and 72 carrier designs
- Clean and oil-free
- Soft texture allows for easy trimming and quicker hose assembly fabrication
- Long mill lengths for less waste
- Engineered for optimal hose coverage
- Manufactured on OmegaFlex hose mandrels to ensure proper braid angle

Abrasion Resistant Tubular Braid for Series 300 Hose — Stainless Steel T304

| Nominal Hose Size (in.) | Diameter Hose Size (DN) | Braid Type | Braid Construction | Braid I.D. (in.) | Braid Coverage (%) | Max. Working Pressure at 70°F (PSIG) ^{a, b} | Weight Per Foot (lb.) | Typical Mill Length (ft.) ^c |
|-------------------------|-------------------------|------------|--------------------|------------------|--------------------|--|-----------------------|--|
| ¼ | 8 | H | 24 x 7 x .012 | 0.46 | 96 | 2375 | 0.130 | 30-100 |
| ⅜ | 10 | H | 24 x 8 x .016 | 0.61 | 94 | 1650 | 0.168 | 30-100 |
| ½ | 15 | H | 24 x 8 x .016 | 0.76 | 95 | 1100 | 0.200 | 30-100 |
| ¾ | 20 | H | 36 x 7 x .020 | 1.05 | 94 | 800 | 0.310 | 30-100 |
| 1 | 25 | H | 36 x 6 x .024 | 1.34 | 95 | 750 | 0.450 | 30-100 |
| 1¼ | 32 | H | 48 x 7 x .024 | 1.64 | 98 | 725 | 0.600 | 30-60 |
| 1½ | 40 | H | 48 x 7 x .024 | 1.90 | 95 | 565 | 0.700 | 30-60 |
| 2 | 50 | H | 48 x 7 x .028 | 2.47 | 96 | 500 | 0.874 | 30-60 |
| 2½ | 65 | H | 72 x 8 x .024 | 3.33 | 97 | 400 | 1.127 | 30-60 |
| 3 | 80 | H | 72 x 9 x .024 | 3.89 | 97 | 288 | 1.430 | 30-60 |
| 4 | 100 | H | 72 x 10 x .024 | 4.83 | 96 | 250 | 1.535 | 30-50 |

a. Maximum working pressure shown is calculated for OmegaFlex annular hose and corresponding single layer braid. See Series 300 annular hose specifications for additional information.

b. Abrasion resistant braid in abrasive environments extends hose life. Abrasive Resistant braid is not intended for use in high pressure applications — see Series 800 high pressure hose specifications on page 10.

c. Consult factory for longer lengths.

Specifying Part Numbers for Abrasion Resistant Braid Products

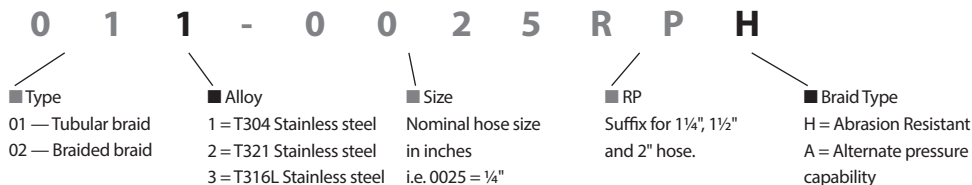

STAINLESS High Pressure

Series 800 ISO 10380 Qualified

- 812 Series manufactured with 321 stainless steel hose with 304 stainless steel braid
- 813 Series manufactured in T316 stainless steel hose with T316 stainless steel braid
- Pressure capability includes full vacuum to pressures shown below
- Temperature ratings from cryogenic to 1500°F
- Consult Temperature Correction Table on page 39 for concurrent high temperature/high pressure applications
- Meets or exceeds ISO 10380^b
- Sold only as braided hose

Series 800 — Annular, Stainless Steel, High Pressure Hose and Braid

| Nominal Hose Size (in.) | Diameter Hose Size (DN) | Braid Layers | Nominal Outside Diameter | Nominal Inside Diameter | Minimum Centerline Bend Radius (in.) | | Pressure ratings at 70°F (PSIG) ^{a,b,c} | | | Braid Sleeve Crimp O.D.d (in.) | Weight per Foot (lb.) |
|-------------------------|-------------------------|--------------|--------------------------|-------------------------|--------------------------------------|---------|--|--------------|---------------|--------------------------------|-----------------------|
| | | | | | Static | Dynamic | Maximum Working | Maximum Test | Nominal Burst | | |
| ¼ ^e | 8 | 1 | .51 | 0.32 | 2.25 | 4.5 | 2500 | 3750 | 10000 | 0.59 | 0.19 |
| | | 2 | .56 | | 3 | 6 | 3250 | 4875 | 13000 | 0.64 | 0.30 |
| ⅜ | 10 | 1 | .67 | 0.42 | 3 | 6 | 2625 | 3938 | 10500 | 0.78 | 0.31 |
| | | 2 | .73 | | 4 | 8 | 3250 | 4875 | 13000 | 0.87 | 0.51 |
| ½ | 15 | 1 | .83 | 0.53 | 4.5 | 7.5 | 2000 | 3000 | 8000 | 0.93 | 0.39 |
| | | 2 | .89 | | 6 | 10 | 3200 | 4800 | 12800 | 1.03 | 0.63 |
| ¾ | 20 | 1 | 1.16 | 0.81 | 6 | 9 | 1525 | 2288 | 6100 | 1.27 | 0.59 |
| | | 2 | 1.26 | | 8 | 12 | 2625 | 3938 | 10500 | 1.37 | 0.96 |
| 1 | 25 | 1 | 1.43 | 1.03 | 6.75 | 10.5 | 1375 | 2063 | 5500 | 1.57 | 0.73 |
| | | 2 | 1.54 | | 9 | 14 | 2050 | 3075 | 8200 | 1.71 | 1.10 |
| 1¼ | 32 | 1 | 1.87 | 1.26 | 4.5 | 13.5 | 1125 | 1688 | 4500 | 2.02 | 1.32 |
| | | 2 | 1.98 | | 6 | 18 | 1800 | 2700 | 7200 | 2.19 | 2.02 |
| 1½ | 40 | 1 | 2.19 | 1.55 | 5.25 | 16.5 | 1025 | 1538 | 4100 | 2.32 | 1.56 |
| | | 2 | 2.25 | | 7 | 22 | 1750 | 2625 | 7000 | 2.46 | 2.55 |
| 2 | 50 | 1 | 2.65 | 2.00 | 6.75 | 18 | 850 | 1275 | 3400 | 2.83 | 1.93 |
| | | 2 | 2.78 | | 9 | 24 | 1325 | 1988 | 5300 | 2.94 | 3.14 |
| 2½ | 65 | 1 | 3.42 | 2.61 | 7.5 | 19.5 | 625 | 938 | 2500 | — | 2.72 |
| | | 2 | 3.53 | | 10 | 26 | 1125 | 1688 | 4500 | — | 4.23 |
| 3 | 80 | 1 | 3.98 | 3.10 | 11.25 | 24 | 563 | 844 | 2250 | — | 3.20 |
| | | 2 | 4.09 | | 15 | 32 | 1000 | 1500 | 4000 | — | 4.72 |
| 4 | 100 | 1 | 4.92 | 3.98 | 15 | 30 | 363 | 544 | 1450 | — | 3.79 |
| | | 2 | 5.03 | | 20 | 40 | 625 | 938 | 2500 | — | 5.48 |
| 5 | 125 | 1 | 5.85 | 5.03 | 20 | 40 | 300 | 450 | 1200 | — | 6.02 |
| | | 2 | 5.98 | | 25 | 50 | 500 | 750 | 2000 | — | 9.03 |
| 6 | 150 | 1 | 7.12 | 6.03 | 22.5 | 45 | 275 | 413 | 1100 | — | 7.01 |
| | | 2 | 7.26 | | 30 | 60 | 413 | 619 | 1650 | — | 9.57 |
| 8 | 200 | 1 | 9.34 | 7.96 | 30 | 60 | 200 | 300 | 800 | — | 11.38 |
| | | 2 | 9.56 | | 40 | 80 | 300 | 450 | 1200 | — | 15.45 |

- a. OmegaFlex hose and corresponding braid must be used in combination to achieve pressure ratings.
 b. Hose sizes ¾" through 2" meet ISO 10380 cycle life requirement of 50,000 minimum average cycles at maximum rated working pressure listed above.
 c. Assemblies in sizes 2½" through 8" must incorporate pullover braid with neck down design to meet listed pressure ratings. Contact OmegaFlex for details on this procedure.
 d. Braid sleeve must be crimped to the listed braid sleeve crimp O.D. on sizes 2" and below in order to meet pressure ratings. Consult OmegaFlex for details.
 e. 1/4" meets ISO 10380 cycle life requirements at OmegaFlex specified bend radius.

Specifying Part Numbers for Series 800 Products

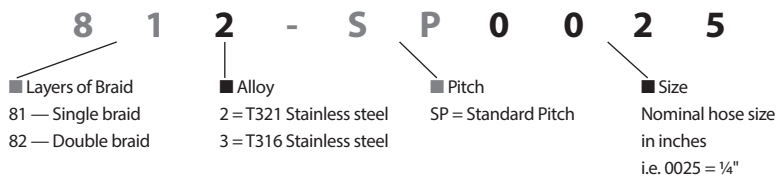

STAINLESS Hose

Series 100

ISO 10380 Qualified

- Available in 304, 321, 316L stainless steel and other materials on request
- Pressure capability includes full vacuum to pressures shown below
- Consult Temperature Correction Table on page 39 for concurrent high temperature/high pressure applications
- Temperature rating from cryogenic to 1500°F
- Hose corrugation designs include Standard Pitch, Open Pitch and Superflex. Contact OmegaFlex for specifications on Open Pitch and Superflex.
- Unique self-draining found only in helical corrugations

Series 100 — Helical, Stainless Steel, Standard Pitch Hose

| Nominal Hose Size (in.) | Diameter Hose Size (DN) | Braid Layers/Type | Nominal Outside Diameter | Nominal Inside Diameter | Minimum Centerline Bend Radius (in.) | | Pressure ratings at 70°F (PSIG) ^a | | | Weight per Foot (lb.) | Typical Mill Length (ft.) ^b |
|-------------------------|-------------------------|-------------------|--------------------------|-------------------------|--------------------------------------|---------|--|-----------|---------------|-----------------------|--|
| | | | | | Static | Dynamic | Max. Working | Max. Test | Nominal Burst | | |
| ¼" | 8 | 0 | 0.44 | 0.30 | 4 | 6 | 140 | 210 | — | 0.08 | 30-100 |
| | | 1 | 0.49 | | | | 2625 | 3938 | 10500 | 0.17 | |
| | | 2 | 0.54 | | | | 3625 | 5438 | 14500 | 0.26 | |
| ⅜" | 10 | 0 | 0.60 | 0.39 | 2 | 4 | 100 | 150 | — | 0.12 | 30-100 |
| | | 1 | 0.66 | | | | 1650 | 2475 | 6600 | 0.23 | |
| | | 2 | 0.72 | | | | 2200 | 3300 | 8800 | 0.35 | |
| ½" | 15 | 0 | 0.73 | 0.51 | 3 | 5 | 75 | 113 | — | 0.16 | 30-100 |
| | | 1 | 0.78 | | | | 1150 | 1725 | 4600 | 0.26 | |
| | | 2 | 0.84 | | | | 1750 | 2625 | 7000 | 0.37 | |
| ¾" | 20 | 0 | 1.00 | 0.76 | 4 | 6 | 50 | 75 | — | 0.24 | 30-100 |
| | | 1 | 1.05 | | | | 800 | 1200 | 3600 | 0.41 | |
| | | 2 | 1.11 | | | | 1250 | 1875 | 4800 | 0.60 | |
| 1" | 25 | 0 | 1.28 | 1.00 | 4.5 | 7 | 50 | 75 | — | 0.34 | 30-100 |
| | | 1 | 1.36 | | | | 750 | 1125 | 3000 | 0.60 | |
| | | 2 | 1.44 | | | | 1050 | 1575 | 4200 | 0.89 | |

a. OmegaFlex hose and corresponding braid must be used in combination to achieve pressure ratings.

b. Consult factory for longer lengths.

c. ¼" meets ISO 10380 cycle life requirements at OmegaFlex specified bend radius.

Hose-On-Reel

- Braided "sausage link" fashion
- Hose mill lengths from 30 feet to 100 feet
- Convenient handling, storage and inventory control
- Also available in double braid construction

Series 100 Braided Helical Hose-On-Reel, Single Braid^a

| Nominal Hose Size (in.) | Diameter Hose Size (DN) | Reel Quantity (ft.) | Reel Flange (in.) | Reel Width (in.) | Weight per Reel (lb.) |
|-------------------------|-------------------------|---------------------|-------------------|------------------|-----------------------|
| ¼" | 8 | 400 | 24 | 13 | 93 |
| ⅜" | 10 | 400 | 24 | 13 | 117 |
| ½" | 15 | 400 | 24 | 13 | 129 |
| ¾" | 20 | 300 | 28 | 15 | 148 |
| 1" | 25 | 200 | 28 | 15 | 145 |

a. Use chart above for single braided hose specifications.

Specifying Part Numbers for Series 100 Products

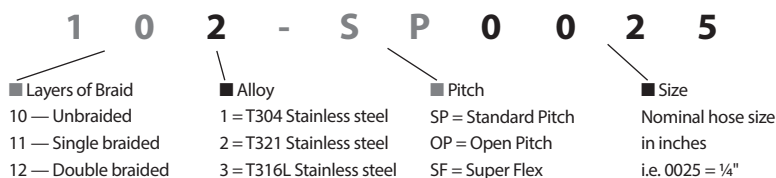

STAINLESS Braid

Tubular Braid

- Wide range of constructions including 24, 36, 48 and 72 carrier designs
- Clean and oil-free
- Long mill lengths for less waste
- Engineered for optimal hose coverage
- Excellent Chemical resistance to dry chlorine, salt water, and alkalines
- Manufactured on OmegaFlex hose mandrels to ensure proper braid angle
- Custom braiding to customer specifications is available in 304, 321 and 316L stainless steel, bronze, monel, exotic alloys and synthetic materials

Tubular Braid for Series 100 Hose — Stainless Steel T304, T321 and T316

| Nominal Hose Size (in.) | Diameter Hose Size (DN) | Braid Construction | Braid I.D. (in.) | Braid Coverage (%) | Max. Working Pressure at 70°F (PSIG) ^a | Weight Per Foot (lb.) | Typical Mill Length (ft.) ^b |
|-------------------------|-------------------------|--------------------|------------------|--------------------|---|-----------------------|--|
| ¼ | 8 | 24 x 6 x .012 | 0.44 | 90 | 2625 | 0.065 | 30-100 |
| ⅜ | 10 | 24 x 8 x .012 | 0.60 | 94 | 1650 | 0.098 | 30-100 |
| ½ | 15 | 24 x 8 x .012 | 0.73 | 86 | 1150 | 0.101 | 30-100 |
| ¾ | 20 | 36 x 8 x .012 | 1.00 | 90 | 800 | 0.143 | 30-100 |
| 1 | 25 | 36 x 8 x .016 | 1.28 | 88 | 750 | 0.268 | 30-100 |

a. Maximum working pressure shown is calculated for OmegaFlex helical hose and corresponding single layer braid. See Series 100 helical hose specifications for additional information.

b. Consult factory for longer lengths.

Abrasion Resistant Tubular Braid for Series 100 Hose — Stainless Steel T304

| Nominal Hose Size (in.) | Diameter Hose Size (DN) | Braid Type ^a | Braid Construction | Braid I.D. (in.) | Braid Coverage (%) | Max. Working Pressure at 70°F (PSIG) ^b | Weight Per Foot (lb.) | Typical Mill Length (ft.) ^c |
|-------------------------|-------------------------|-------------------------|--------------------|------------------|--------------------|---|-----------------------|--|
| ¼ | 8 | H | 24 x 7 x .012 | 0.44 | 96 | 2625 | 0.130 | 30-100 |
| ⅜ | 10 | H | 24 x 8 x .016 | 0.60 | 94 | 1650 | 0.168 | 30-100 |
| ½ | 15 | H | 24 x 8 x .016 | 0.73 | 95 | 1150 | 0.200 | 30-100 |
| ¾ | 20 | H | 36 x 7 x .020 | 1.00 | 94 | 800 | 0.310 | 30-100 |
| 1 | 25 | H | 36 x 6 x .024 | 1.28 | 95 | 750 | 0.450 | 30-100 |

a. Abrasion resistant braid in abrasive environments extends hose life. Abrasion Resistant braid is not intended for use in high pressure applications — see Series 800 high pressure hose specifications on page 10.

b. Maximum working pressure shown is calculated for OmegaFlex helical hose and corresponding single layer braid. See Series 100 helical hose specifications for additional information.

c. Consult factory for longer lengths.

Specifying Part Numbers for Helical Braid Products

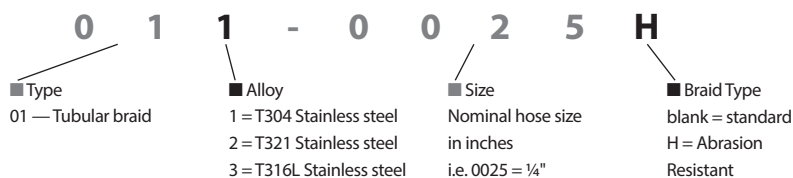

BRONZE Hose

Series 400

- Core material is copper alloy C51000 (95/5)
- Braid material is commercial bronze C22000 (90/10)
- Pressure capability includes full vacuum to pressures shown below
- Temperatures to 400°F
- Material properties allow for unique flexing capabilities
- Designed to maintain pipeline material integrity and prevent galvanic corrosion

Series 400 — Annular, Bronze, Standard Pitch Hose

| Nominal Size (in.) | Nominal Size (in.) | Braid/Layers Type | Nominal Outside Diameter | Nominal Inside Diameter | Minimum Centerline Bend Radius (in.) | | Pressure ratings at 70°F (PSIG) ^{a,b} | | | Weight per Foot (lb.) | Typical Mill Length (ft.) ^c |
|--------------------|--------------------|-------------------|--------------------------|-------------------------|--------------------------------------|---------|--|-----------|---------------|-----------------------|--|
| | | | | | Static | Dynamic | Max. Working | Max. Test | Nominal Burst | | |
| ¼ | 8 | 0 | 0.46 | 0.31 | 2 | 6 | 120 | 180 | — | 0.12 | 30–100 |
| | | 1 | 0.52 | | | | 934 | 1401 | 3735 | 0.22 | |
| | | 2 | 0.57 | | | | 1242 | 1863 | 4968 | 0.32 | |
| ¾ | 10 | 0 | 0.61 | 0.42 | 2 | 6 | 60 | 90 | — | 0.16 | 30–100 |
| | | 1 | 0.67 | | | | 704 | 1056 | 2815 | 0.29 | |
| | | 2 | 0.73 | | | | 936 | 1404 | 3744 | 0.42 | |
| ½ | 15 | 0 | 0.76 | 0.54 | 2.25 | 7 | 50 | 75 | — | 0.23 | 30–100 |
| | | 1 | 0.81 | | | | 566 | 849 | 2265 | 0.38 | |
| | | 2 | 0.87 | | | | 753 | 1130 | 3012 | 0.53 | |
| ¾ | 20 | 0 | 1.05 | 0.81 | 2.5 | 8 | 30 | 45 | — | 0.33 | 30–100 |
| | | 1 | 1.10 | | | | 468 | 701 | 1870 | 0.55 | |
| | | 2 | 1.16 | | | | 622 | 933 | 2487 | 0.77 | |
| 1 | 25 | 0 | 1.35 | 1.03 | 3 | 9 | 26 | 39 | — | 0.41 | 30–100 |
| | | 1 | 1.42 | | | | 334 | 501 | 1335 | 0.68 | |
| | | 2 | 1.50 | | | | 444 | 666 | 1776 | 0.95 | |
| 1¼ | 32 | 0 | 1.66 | 1.30 | 3.5 | 10 | 16 | 24 | — | 0.71 | 30–60 |
| | | 1 | 1.74 | | | | 306 | 459 | 1225 | 1.15 | |
| | | 2 | 1.82 | | | | 407 | 611 | 1629 | 1.59 | |
| 1½ | 40 | 0 | 1.89 | 1.51 | 4 | 10 | 15 | 22.5 | — | 0.93 | 30–60 |
| | | 1 | 1.96 | | | | 297 | 445 | 1187 | 1.47 | |
| | | 2 | 2.03 | | | | 395 | 592 | 1579 | 2.01 | |
| 2 | 50 | 0 | 2.48 | 2.05 | 6 | 11 | 10 | 15 | — | 1.00 | 30–60 |
| | | 1 | 2.57 | | | | 210 | 315 | 840 | 1.62 | |
| | | 2 | 2.66 | | | | 279 | 419 | 1117 | 2.24 | |
| 2½ | 65 | 0 | 3.30 | 2.62 | 8.5 | 16 | 8 | 12 | — | 1.70 | 7–20 |
| | | 1 | 3.45 | | | | 194 | 291 | 775 | 2.68 | |
| | | 2 | 3.57 | | | | 258 | 387 | 1031 | 3.66 | |
| 3 | 80 | 0 | 3.88 | 3.13 | 10 | 20 | 5 | 8 | — | 2.10 | 7–20 |
| | | 1 | 4.01 | | | | 166 | 249 | 665 | 3.30 | |
| | | 2 | 4.13 | | | | 221 | 332 | 884 | 4.50 | |
| 4 | 100 | 0 | 4.84 | 3.97 | 12 | 24 | 3 | 4.5 | — | 2.31 | 7–20 |
| | | 1 | 4.99 | | | | 145 | 217 | 580 | 3.77 | |
| | | 2 | 5.19 | | | | 192 | 288 | 770 | 5.39 | |

- a. OmegaFlex hose and corresponding braid must be used in combination to achieve pressure ratings.
 b. Contact OmegaFlex for higher maximum working pressures.
 c. Consult factory for longer lengths.

Specifying Part Numbers for Series 400 Products

4 0 4 A - S P 0 0 2 5 R P

- Layers of Braid
40 — Unbraided
41 — Single braided
42 — Double braided
- Alloy/Design
4A = Bronze annular hose
- Pitch
SP = Standard Pitch
- Size
Nominal hose size in inches
i.e. 0025 = ¼"
- RP
Suffix for 1¼", 1½" and 2" hose.



BRONZE Braid

Tubular Braid

- Wide range of constructions including 24, 36, 48 and 72 carrier designs
- Clean and oil-free
- Long mill lengths for less waste
- Engineered for optimal hose coverage
- Manufactured on OmegaFlex hose mandrels to ensure proper braid angle
- Custom braiding to customer specifications is available in 304, 321 and 316L stainless steel, bronze, monel, exotic alloys and synthetic materials

Bronze Tubular Braid for Series 400 Hose

| Nominal Hose Size (in.) | Diameter Hose Size (DN) | Braid Construction | Braid I.D. (in.) | Braid Coverage (%) | Max. Working Pressure at 70°F (PSIG) ^a | Weight Per Foot (lb.) | Typical Mill Length (ft.) ^b |
|-------------------------|-------------------------|--------------------|------------------|--------------------|---|-----------------------|--|
| ¼ | 8 | 24 x 5 x .014 | 0.46 | 94 | 934 | 0.100 | 30–100 |
| ⅜ | 10 | 24 x 7 x .014 | 0.61 | 97 | 704 | 0.130 | 30–100 |
| ½ | 15 | 24 x 8 x .014 | 0.75 | 95 | 566 | 0.150 | 30–100 |
| ¾ | 20 | 36 x 8 x .014 | 1.04 | 95 | 468 | 0.220 | 30–100 |
| 1 | 25 | 36 x 5 x .020 | 1.34 | 80 | 334 | 0.270 | 30–100 |
| 1¼ | 32 | 48 x 6 x .020 | 1.78 | 91 | 306 | 0.440 | 30–60 |
| 1½ | 40 | 48 x 7 x .020 | 2.09 | 88 | 297 | 0.540 | 30–60 |
| 2 | 50 | 48 x 8 x .020 | 2.54 | 85 | 210 | 0.620 | 30–60 |
| 2½ | 65 | 72 x 8 x .020 | 3.33 | 90 | 194 | 0.980 | 30–60 |
| 3 | 80 | 72 x 10 x .020 | 3.89 | 95 | 166 | 1.200 | 30–60 |
| 4 | 100 | 72 x 12 x .020 | 4.79 | 95 | 145 | 1.460 | 30–50 |

a. Maximum working pressure shown is calculated for OmegaFlex bronze hose and corresponding single layer bronze braid. See Series 400 annular bronze hose specifications for additional information.

b. Consult factory for longer lengths.

Specifying Part Numbers for Bronze Braid Products

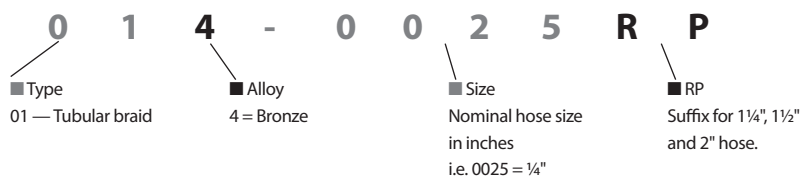

MONEL Hose

Series 500

- Core and braid material is Monel 400 and meets material requirements of the Chlorine Institute Pamphlet 6
- Pressure capability includes full vacuum to pressures shown below
- Temperatures to 800°F
- Excellent chemical resistance to dry chlorine, salt water and alkalines

Series 500 — Annular, Monel, Standard Pitch Hose

| Nominal Hose Size (in.) | Diameter Hose Size (DN) | Braid Layers/Type | Nominal Outside Diameter | Minimum Centerline Bend Radius (in.) | | Pressure ratings at 70°F (PSIG) ^a | | | Weight per Foot (lb.) | Typical Mill Length (ft.) ^b |
|-------------------------|-------------------------|-------------------|--------------------------|--------------------------------------|---------|--|-----------|---------------|-----------------------|--|
| | | | | Static | Dynamic | Max. Working | Max. Test | Nominal Burst | | |
| ¼ | 8 | 0 | 0.46 | 2 | 6 | 130 | 195 | — | 0.13 | 30–100 |
| | | 1 | 0.52 | | | 1701 | 2552 | 6805 | 0.21 | |
| | | 2 | 0.57 | | | 2416 | 3624 | 9664 | 0.29 | |
| ⅜ | 10 | 0 | 0.61 | 2 | 6 | 90 | 135 | — | 0.16 | 30–100 |
| | | 1 | 0.67 | | | 1272 | 1908 | 5087 | 0.27 | |
| | | 2 | 0.73 | | | 1953 | 2930 | 7812 | 0.40 | |
| ½ | 15 | 0 | 0.76 | 2.5 | 7 | 65 | 98 | — | 0.19 | 30–100 |
| | | 1 | 0.81 | | | 852 | 1277 | 3406 | 0.31 | |
| | | 2 | 0.87 | | | 1346 | 2019 | 5385 | 0.43 | |
| ¾ | 20 | 0 | 1.05 | 2.5 | 8 | 50 | 75 | — | 0.28 | 30–100 |
| | | 1 | 1.10 | | | 709 | 1063 | 2835 | 0.43 | |
| | | 2 | 1.16 | | | 1161 | 1741 | 4643 | 0.60 | |
| 1 | 25 | 0 | 1.35 | 3 | 9 | 35 | 52.5 | — | 0.50 | 30–100 |
| | | 1 | 1.42 | | | 692 | 1038 | 2769 | 0.77 | |
| | | 2 | 1.50 | | | 1133 | 1700 | 4533 | 1.08 | |
| 1¼ | 32 | 0 | 1.75 | 4 | 10 | 20 | 30 | — | 0.64 | 7–20 |
| | | 1 | 1.86 | | | 611 | 917 | 2445 | 0.98 | |
| | | 2 | 1.94 | | | 991 | 1486 | 3962 | 1.36 | |
| 1½ | 40 | 0 | 2.08 | 4 | 10 | 15 | 22.5 | — | 0.78 | 7–20 |
| | | 1 | 2.16 | | | 419 | 629 | 1677 | 1.18 | |
| | | 2 | 2.24 | | | 769 | 1153 | 3075 | 1.62 | |
| 2 | 50 | 0 | 2.54 | 6 | 11 | 10 | 15 | — | 0.97 | 7–20 |
| | | 1 | 2.63 | | | 313 | 469 | 1250 | 1.45 | |
| | | 2 | 2.73 | | | 616 | 924 | 2463 | 1.99 | |
| 3 | 80 | 0 | 3.85 | 10 | 20 | 7 | 10.5 | — | 1.77 | 7–20 |
| | | 1 | 4.01 | | | 300 | 450 | 1200 | 2.67 | |
| | | 2 | 4.13 | | | 500 | 750 | 2000 | 3.67 | |
| 4 | 100 | 0 | 4.79 | 12 | 24 | 4 | 6 | — | 2.08 | 7–20 |
| | | 1 | 4.99 | | | 263 | 394 | 1050 | 3.54 | |
| | | 2 | 5.19 | | | 438 | 656 | 1750 | 5.17 | |

a. OmegaFlex hose and corresponding braid must be used in combination to achieve pressure ratings.

b. Consult factory for longer lengths.

Specifying Part Numbers for Series 500 Products

5 0 5 A - S P 0 0 2 5

- Layers of Braid
50 — Unbraided
51 — Single braid
52 — Double braid
- Alloy
5A = Monel Annular Hose
- Pitch
SP = Standard Pitch
- Size
Nominal hose size in inches
i.e. 0025 = ¼"

Omega Flex, Inc.,
451 Creamery Way, Exton, PA 19341-2509 Tel:1-610-524-7272 FAX:1-610-524-6484 www.omegaflex.com

Call 1-800-355-1039



MONEL Braid

Tubular Braid

- Wide range of constructions including 24, 36, 48 and 72 carrier designs
- Clean and oil-free
- Long mill lengths for less waste
- Engineered for optimal hose coverage
- Manufactured on OmegaFlex hose mandrels to ensure proper braid angle
- Custom braiding to customer specifications is available in 304, 321 and 316L stainless steel, bronze, monel, exotic alloys and synthetic materials

Monel Tubular Braid for Series 500 Hose

| Nominal Hose Size (in.) | Diameter Hose Size (DN) | Braid Construction | Braid I.D. (in.) | Braid Coverage (%) | Max. Working Pressure at 70°F (PSIG) ^a | Weight Per Foot (lb.) | Approx. Mill Length (ft.) ^b |
|-------------------------|-------------------------|--------------------|------------------|--------------------|---|-----------------------|--|
| ¼ | 8 | 24 X 6 X .012 | 0.46 | 90 | 1701 | 0.075 | 30-100 |
| ⅜ | 10 | 24 X 8 X .012 | 0.61 | 94 | 1272 | 0.112 | 30-100 |
| ½ | 15 | 24 X 8 X .012 | 0.75 | 85 | 852 | 0.116 | 30-100 |
| ¾ | 20 | 36 X 8 X .012 | 1.04 | 89 | 709 | 0.152 | 30-100 |
| 1 | 25 | 36 X 8 X .016 | 1.34 | 88 | 692 | 0.274 | 30-100 |
| 1¼ | 32 | 48 X 8 X .016 | 1.78 | 90 | 611 | 0.342 | 30-60 |
| 1½ | 40 | 48 X 8 X .016 | 2.09 | 84 | 419 | 0.400 | 30-60 |
| 2 | 50 | 48 X 8 X .020 | 2.54 | 88 | 313 | 0.483 | 30-60 |
| 3 | 80 | 72 X 10 X .020 | 3.89 | 95 | 300 | 1.130 | 30-60 |
| 4 | 100 | 72 X 12 X .020 | 4.79 | 95 | 263 | 1.463 | 30-50 |

a. Maximum working pressure shown is calculated for OmegaFlex monel hose and corresponding single layer monel braid. See Series 500 annular monel hose specifications for additional information.

b. Consult factory for longer lengths.

Specifying Part Numbers for Monel Braid Products

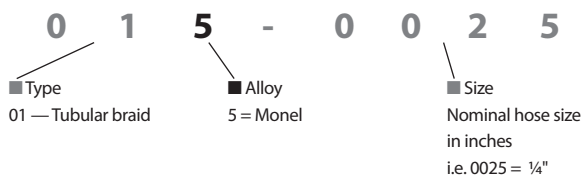

INCONEL Hose

Series 600

- Core Material is Nickel-Chromium-Molybdenum-Columbium N06625
- Braid Material is Nickel-Chromium-Iron N06025
- Pressure capability includes full vacuum to pressures show below
- Temperatures to 1,500°F
- Excellent corrosion resistance at high temperature

Series 600 - Annular, Inconel, Standard Pitch Hose

| Nominal Hose Size (in.) | Diameter Hose Size (DN) | Braid Layers/Type | Nominal Outside Diameter | Nominal Inside Diameter | Minimum Centerline Bend Radius (In.) | | Pressure Ratings at 70°F(PSIG) | | | Weight Per Foot (lb.) | Typical Mill Length (ft.) |
|-------------------------|-------------------------|-------------------|--------------------------|-------------------------|--------------------------------------|---------|--------------------------------|----------|---------------|-----------------------|---------------------------|
| | | | | | Static | Dynamic | Max Working | Max Test | Nominal Burst | | |
| ¼ | 8 | 0 | 0.46 | 0.32 | 4 | 6 | 140 | 210 | - | 0.09 | 30-100 |
| | | 1 | 0.51 | | | | 2375 | 3563 | 9500 | 0.19 | |
| | | 2 | 0.56 | | | | 3125 | 4688 | 12500 | 0.28 | |
| ⅜ | 10 | 0 | 0.61 | 0.42 | 2 | 4 | 100 | 150 | - | 0.13 | 30-100 |
| | | 1 | 0.67 | | | | 1650 | 2475 | 6600 | 0.24 | |
| | | 2 | 0.73 | | | | 2200 | 3300 | 8800 | 0.36 | |
| ½ | 15 | 0 | 0.76 | 0.55 | 3 | 5 | 75 | 113 | - | 0.17 | 30-100 |
| | | 1 | 0.81 | | | | 1100 | 1650 | 4400 | 0.29 | |
| | | 2 | 0.87 | | | | 1625 | 2438 | 6500 | 0.41 | |
| ¾ | 20 | 0 | 1.05 | 0.81 | 4 | 6 | 50 | 75 | - | 0.27 | 30-100 |
| | | 1 | 1.10 | | | | 800 | 1200 | 3200 | 0.45 | |
| | | 2 | 1.16 | | | | 1250 | 1875 | 5000 | 0.63 | |
| 1 | 25 | 0 | 1.34 | 1.03 | 4.5 | 7 | 50 | 75 | - | 0.38 | 30-100 |
| | | 1 | 1.42 | | | | 750 | 1125 | 3000 | 0.65 | |
| | | 2 | 1.50 | | | | 1000 | 1500 | 4000 | 0.92 | |
| 1¼ | 32 | 0 | 1.78 | 1.26 | 4 | 11 | 25 | 37.5 | - | 0.52 | 7-20 |
| | | 1 | 1.86 | | | | 725 | 1088 | 2900 | 0.94 | |
| | | 2 | 1.94 | | | | 1100 | 1650 | 4400 | 1.36 | |
| 1½ | 40 | 0 | 2.10 | 1.55 | 4.5 | 12 | 20 | 30 | - | 0.56 | 7-20 |
| | | 1 | 2.16 | | | | 565 | 850 | 2260 | 0.99 | |
| | | 2 | 2.23 | | | | 887 | 1330 | 3550 | 1.42 | |
| 2 | 50 | 0 | 2.54 | 2.00 | 5 | 13 | 16 | 24 | - | 0.76 | 7-20 |
| | | 1 | 2.65 | | | | 500 | 750 | 2000 | 1.50 | |
| | | 2 | 2.76 | | | | 750 | 1050 | 3000 | 2.24 | |
| 3 | 80 | 0 | 3.89 | 3.10 | 7.5 | 16 | 8 | 12 | - | 1.61 | 7-20 |
| | | 1 | 4.01 | | | | 288 | 431 | 1150 | 2.52 | |
| | | 2 | 4.13 | | | | 431 | 647 | 1725 | 3.43 | |
| 4 | 100 | 0 | 4.83 | 3.98 | 10 | 20 | 5 | 7.5 | - | 2.06 | 7-20 |
| | | 1 | 5.03 | | | | 250 | 375 | 1000 | 3.26 | |
| | | 2 | 5.23 | | | | 375 | 563 | 1500 | 4.46 | |

a. Omegaflex hose and corresponding braid must be used in combination to achieve pressure ratings
 b. Consult factory for longer lengths

Specifying Part Numbers for Series 600 Products

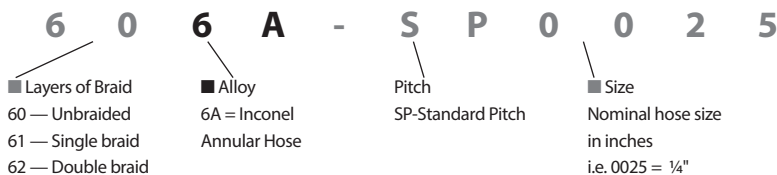

Omega Flex, Inc.,
 451 Creamery Way, Exton, PA 19341-2509 Tel:1-610-524-7272 FAX:1-610-524-6484 www.omegaflex.com

Call 1-800-355-1039



INCONEL Braid

Tubular Braid

- Wide range of constructions including 24, 36, 48 and 72 carrier designs
- Clean and oil-free
- Long mill lengths for less waste
- Engineered for optimal hose coverage
- Excellent Chemical resistance to dry chlorine, salt water, and alkalines
- Manufactured on OmegaFlex hose mandrels to ensure proper braid angle
- Custom braiding to customer specifications is available in 304, 321 and 316L stainless steel, bronze, monel, exotic alloys and synthetic materials

Inconel Tubular Braid for Series 600 Hose

| Nominal Hose Size (in.) | Diameter Hose Size (DN) | Braid Construction | Braid I.d. (in.) | Braid Coverage (%) | Max. Working Pressure at 70°F (PSIG) | Weight Per Foot (lb.) | Typical Mill Length (ft.) |
|-------------------------|-------------------------|--------------------|------------------|--------------------|--------------------------------------|-----------------------|---------------------------|
| ¼ | 8 | 24 X 6 X .012 | 0.46 | 90 | 2375 | 0.10 | 30-100 |
| ⅜ | 10 | 24 X 8 X .012 | 0.61 | 94 | 1650 | 0.11 | 30-100 |
| ½ | 15 | 24 X 8 X .012 | 0.76 | 86 | 1100 | 0.12 | 30-100 |
| ¾ | 20 | 36 X 8 X .012 | 1.05 | 90 | 800 | 0.18 | 30-100 |
| 1 | 25 | 36 X 6 X .016 | 1.34 | 88 | 750 | 0.27 | 30-100 |
| 1¼ | 32 | 48 X 8 X .016 | 1.78 | 90 | 725 | 0.42 | 30-60 |
| 1½ | 40 | 48 X 8 X .016 | 2.10 | 84 | 565 | 0.43 | 30-60 |
| 2 | 50 | 48 X 8 X .016 | 2.54 | 78 | 500 | 0.74 | 30-60 |
| 3 | 80 | 72 X 8 X .020 | 3.89 | 86 | 288 | 0.91 | 30-60 |
| 4 | 100 | 72 X 10 X .020 | 4.83 | 84 | 250 | 1.20 | 30-50 |

a. Maximum working pressure shown is calculated for OmegaFlex Inconel hose and corresponding single layer Inconel braid. See Inconel hose specifications for additional information.

b. Consult factory for longer lengths

Specifying Part Numbers for Series 600 Products

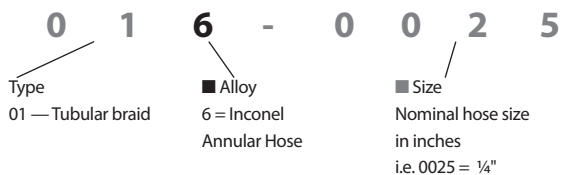

Omega Flex, Inc.,

451 Creamery Way, Exton, PA 19341-2509 Tel:1-610-524-7272 FAX:1-610-524-6484 www.omegaflex.com

Call 1-800-355-1039



HASTELLOY Hose

- Core Material is Low-Carbon Nickel-Molybdenum-Chromium N10276
- Braid Material is Low-Carbon Nickel-Molybdenum-Chromium N10276
- Pressure capability includes full vacuum to pressures show below
- Temperatures to 1,400°F
- Excellent Chemical resistance to dry chlorine, salt water, and alkalines

Series 700

Series 700 - Annular, Hastelloy, Standard Pitch Hose

| Nominal Hose Size (in.) | Diameter Hose Size (DN) | Braid Layers/ Type | Nominal Outside Diameter | Nominal Inside Diameter | Minimum Centerline Bend Radius (In.) Static Dynamic | | Pressure Ratings at 70°F (PSIG) | | | Weight Per Foot (lb.) | Typical Mill Length (ft.) |
|-------------------------|-------------------------|--------------------|--------------------------|-------------------------|--|----|---------------------------------|----------|---------------|-----------------------|---------------------------|
| | | | | | | | Max Working | Max Test | Nominal Burst | | |
| ¼ | 8 | 0 | 0.51 | 0.32 | 4 | 6 | 140 | 210 | - | 0.20 | 30-100 |
| | | 2375 | | | | | 3563 | 9500 | | | |
| | | 3125 | | | | | 4688 | 12500 | | | |
| ¾ | 10 | 0 | 0.67 | 0.42 | 2 | 4 | 100 | 150 | - | 0.26 | 30-100 |
| | | 1650 | | | | | 2475 | 6600 | | | |
| | | 2200 | | | | | 3300 | 8800 | | | |
| ½ | 15 | 0 | 0.81 | 0.55 | 3 | 5 | 75 | 113 | - | 0.31 | 30-100 |
| | | 1100 | | | | | 1650 | 4400 | | | |
| | | 1625 | | | | | 2438 | 6500 | | | |
| ¾ | 20 | 0 | 1.10 | 0.81 | 4 | 6 | 50 | 75 | - | 0.48 | 30-100 |
| | | 800 | | | | | 1200 | 3200 | | | |
| | | 1250 | | | | | 1875 | 5000 | | | |
| 1 | 25 | 0 | 1.34 | 1.03 | 4.5 | 7 | 50 | 75 | - | 0.69 | 30-100 |
| | | 750 | | | | | 1125 | 3000 | | | |
| | | 1000 | | | | | 1500 | 4000 | | | |
| 1¼ | 32 | 0 | 1.78 | 1.26 | 4 | 11 | 25 | 37.5 | - | 0.99 | 7-20 |
| | | 725 | | | | | 1088 | 2900 | | | |
| | | 1100 | | | | | 1650 | 4400 | | | |
| 1½ | 40 | 0 | 2.10 | 1.55 | 4.5 | 12 | 20 | 30 | - | 1.02 | 7-20 |
| | | 565 | | | | | 850 | 2260 | | | |
| | | 887 | | | | | 1330 | 3550 | | | |
| 2 | 50 | 0 | 2.54 | 2.00 | 5 | 13 | 16 | 24 | - | 1.58 | 7-20 |
| | | 500 | | | | | 750 | 2000 | | | |
| | | 750 | | | | | 1050 | 3000 | | | |
| 3 | 80 | 0 | 3.89 | 3.10 | 7.5 | 16 | 8 | 12 | - | 2.65 | 7-20 |
| | | 288 | | | | | 431 | 1150 | | | |
| | | 431 | | | | | 647 | 1725 | | | |
| 4 | 100 | 0 | 4.83 | 3.98 | 10 | 20 | 5 | 7.5 | - | 3.49 | 7-20 |
| | | 250 | | | | | 375 | 1000 | | | |
| | | 375 | | | | | 563 | 1500 | | | |

a. Omegaflex hose and corresponding braid must be used in combination to achieve pressure ratings b. Consult factory for longer lengths

Specifying Part Numbers for Series 600 Products

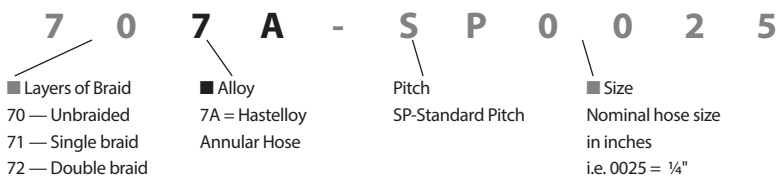

Omega Flex, Inc.,
451 Creamery Way, Exton, PA 19341-2509 Tel:1-610-524-7272 FAX:1-610-524-6484 www.omegaflex.com

Call 1-800-355-1039



HASTELLOY Braid

Tubular Braid

- Wide range of constructions including 24, 36, 48 and 72 carrier designs
- Clean and oil-free
- Long mill lengths for less waste
- Engineered for optimal hose coverage
- Excellent Chemical resistance to dry chlorine, salt water, and alkalines
- Manufactured on OmegaFlex hose mandrels to ensure proper braid angle
- Custom braiding to customer specifications is available in 304, 321 and 316L stainless steel, bronze, monel, exotic alloys and synthetic materials

Hastelloy Tubular Braid for Series 700 Hose

| Nominal Hose Size (in.) | Diameter Hose Size (DN) | Braid Construction | Braid I.d. (in.) | Braid Coverage (%) | Max. Working Pressure at 70°F (PSIG) | Weight Per Foot (lb.) | Typical Mill Length (ft.) |
|-------------------------|-------------------------|--------------------|------------------|--------------------|--------------------------------------|-----------------------|---------------------------|
| ¼ | 8 | 24 X 6 X .012 | 0.46 | 90 | 2375 | 0.10 | 30-100 |
| ⅜ | 10 | 24 X 8 X .012 | 0.61 | 94 | 1650 | 0.11 | 30-100 |
| ½ | 15 | 24 X 8 X .012 | 0.76 | 86 | 1100 | 0.13 | 30-100 |
| ¾ | 20 | 36 X 8 X .012 | 1.05 | 90 | 800 | 0.19 | 30-100 |
| 1 | 25 | 36 X 6 X .016 | 1.34 | 88 | 750 | 0.29 | 30-100 |
| 1¼ | 32 | 48 X 8 X .016 | 1.78 | 90 | 725 | 0.45 | 30-60 |
| 1½ | 40 | 48 X 8 X .016 | 2.10 | 84 | 565 | 0.46 | 30-60 |
| 2 | 50 | 48 X 8 X .016 | 2.54 | 78 | 500 | 0.78 | 30-60 |
| 3 | 80 | 72 X 8 X .020 | 3.89 | 86 | 288 | 0.95 | 30-60 |
| 4 | 100 | 72 X 10 X .020 | 4.83 | 84 | 250 | 1.33 | 30-50 |

a. Maximum working pressure shown is calculated for OmegaFlex Hastelloy hose and corresponding single layer Hastelloy braid. See Series 700 annular Hastelloy hose specifications for additional information.

b. Consult factory for longer lengths

Specifying Part Numbers for Series 700 Products

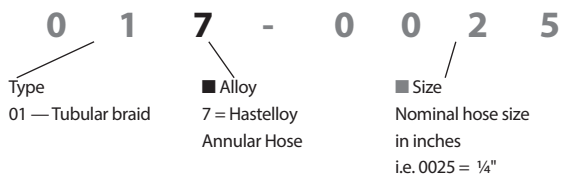

STAINLESS Hose

Series 300

300 Series Extruded (TPV) Hose

OmegaFlex® extruded corrugated braided hose consists of corrugated 300 series stainless steel hose with one layer of 304 stainless steel braid, with an outer jacket of Thermoplastic Vulcanizate (TPV). Several end fitting configurations can be used on the 300 Series extruded (TPV) hose. After fabricating a hose assembly using OmegaFlex' 300 series extruded (TPV) hose, a .070" thick Polyolefin heat shrink sleeve is used to partially cover the end fitting and any exposed braided hose.

300 Series Extruded (TPV) Hose Materials

Hose Material: 300 series stainless steel corrugated hose conforms to ASTM A240.

Braid Material: 304 stainless steel braid conforms to ASTM A580

Jacket Material: Non-Halogenated Thermoplastic Vulcanizate (TPV)

Heat Shrink Sleeve: Polyolefin heat shrinkable sleeve

300 Series Extruded (TPV) Hose Operating Temperatures

-76°F to 275°F

Series 300 — Extruded (TPV) Hose

| 300 Series Extruded Hose Size (in.) | Braided Hose ID (Nom) | Braided Hose OD (Nom) | TPV Jacket OD (Nom) | MAWP (PSIG) at 70°F | Minimum Static Bend Radius (in.) | Minimum Dynamic Bend Radius (in.) | Reel Quantities (ft.) |
|-------------------------------------|-----------------------|-----------------------|---------------------|---------------------|----------------------------------|-----------------------------------|-----------------------|
| ½ | 0.550 | 0.810 | 0.894 | 1100 | 4 | 6 | 250 |
| ¾ | 0.81 | 1.10 | 1.184 | 800 | 5 | 7 | 250 |
| 1 | 1.03 | 1.42 | 1.504 | 750 | 5.5 | 8 | 250 |
| 1½ | 1.53 | 1.95 | 2.07 | 565 | 5.5 | 13 | 250 |
| 2 | 2.05 | 2.58 | 2.70 | 500 | 6 | 14 | 200 |
| 3 | 3.10 | 4.01 | 4.13 | 288 | 8.5 | 17 | 200 |



Figure 1 - Extruded Hose Dimensions

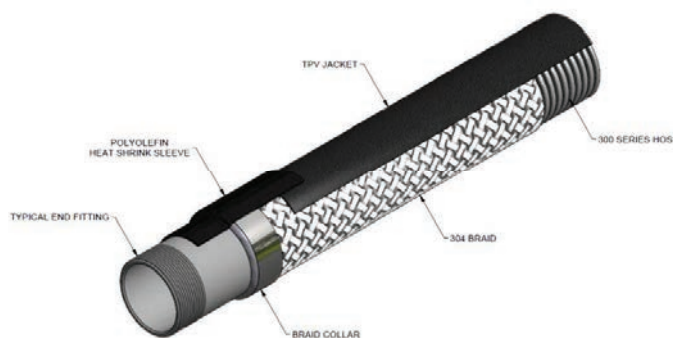

Figure 2 - Typical Hose Assembly with End Fitting

STAINLESS Hose

Series 300

Series 300 — Insulated Extruded (LLDPE) Hose

OmegaFlex® insulated extruded corrugated braided hose consists of corrugated 300 series 316L stainless steel hose with one layer of 304 stainless steel braid, one layer of non-halogenated fiberglass (E-glass) braid with an outer jacket of Linear Low Density Polyethylene (LLDPE), green in color. Several end fitting configurations can be used on the 300 Series insulated extruded (LLDPE) hose. After fabricating a hose assembly using OmegaFlex' 300 series insulated extruded (LLDPE) hose, a .070" thick Polyolefin heat shrink sleeve is used to partially cover the end fitting and any exposed stainless steel/ fiberglass braided hose.

300 Series Insulated Extruded (LLDPE) Hose Materials

Hose Material: 300 series stainless steel corrugated hose conforms to ASTM A240.

Braid Material: 304 stainless steel braid conforms to ASTM A580

Fiberglass Material: Non-halogenated fiberglass (E-glass) braid

Jacket Material: Linear Low Density Polyethylene

Heat Shrink Sleeve: Polyolefin heat shrinkable sleeve

300 Series Insulated Extruded (LLDPE) Hose Operating Temperatures

-76°F to 250°F

Series 300 — Insulated Extruded (LLDPE) Hose

| 300 Series Extruded Hose Size (in.) | OmegaFlex Part Number | Braided Hose ID (Nom) | Braided Hose OD (Nom) | Fiberglass Braid OD (Nom) | LLDPE Jacket OD (Nom) | MAWP (PSIG) at 70°F | Minimum Static Bend Radius (in.) | Minimum Dynamic Bend Radius (in.) | Reel Quantities (ft.) | FG Braid Design |
|-------------------------------------|-----------------------|-----------------------|-----------------------|---------------------------|-----------------------|---------------------|----------------------------------|-----------------------------------|-----------------------|-----------------|
| ¾ | 313-SP0075-FRPLLDPE | 0.810" | 1.100" | 1.330" | 1.450" | 800 | 9 | 18 | 100 | 64X1X1.4 |
| 1 | 313-SP0100-FRPLLDPE | 1.030" | 1.420" | 1.595" | 1.695" | 750 | 12 | 24 | 100 | 64X1X1.4 |



Figure 1 - Insulated Extruded Hose Dimensions

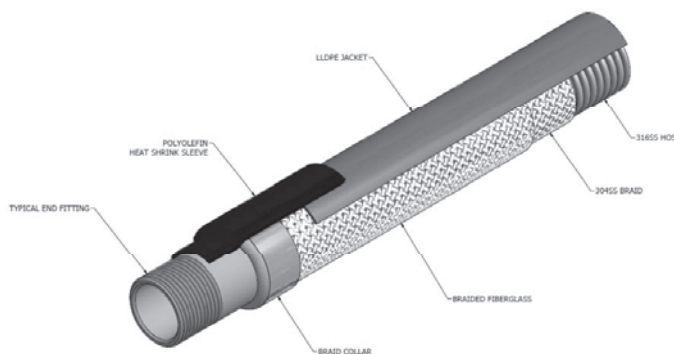

Figure 2 - Typical Hose Assembly with End Fitting

STAINLESS Hose

Series 300

300 Series Extruded (LLDPE) Hose Description

OmegaFlex® extruded corrugated braided hose consists of corrugated 300 series 316L stainless steel hose with one layer of 304 stainless steel braid, with an outer jacket of Linear Low-Density Polyethylene (LLDPE), blue in color. Several end fitting configurations can be used on the 300 Series extruded (LLDPE) hose. After fabricating a hose assembly using OmegaFlex® 300 series extruded (LLDPE) hose a .070" thick Polyolefin heat shrink sleeve is used to partially cover the end fitting and any exposed braided hose.

300 Series Extruded (LLDPE) Hose

Hose Material: 300 series stainless steel corrugated hose conforms to ASTM A240.

Braid Material: 304 stainless steel braid conforms to ASTM A580

Jacket Material: Linear Low-Density Polyethylene (LLDPE)

Heat Shrink Sleeve: Polyolefin heat shrinkable sleeve

300 Series Extruded (LLDPE) Hose Operating Temperatures

-76°F to 250°F

Series 300 — Extruded (LLDPE) Hose

| 300 Series Extruded Hose Size (in.) | OmegaFlex Part Number | Braided Hose ID (Nom) | Braided Hose OD (Nom) | LLDPE Jacket OD (Nom) |
|-------------------------------------|-----------------------|-----------------------|-----------------------|-----------------------|
| 2 | 313-SP0200RP-LPE-BU | 2.05 | 2.58 | 4.08 |
| 3 | 313-SP0300-LPE-BU | 3.10 | 4.08 | 4.25 |



Figure 1 - Extruded Hose Dimensions

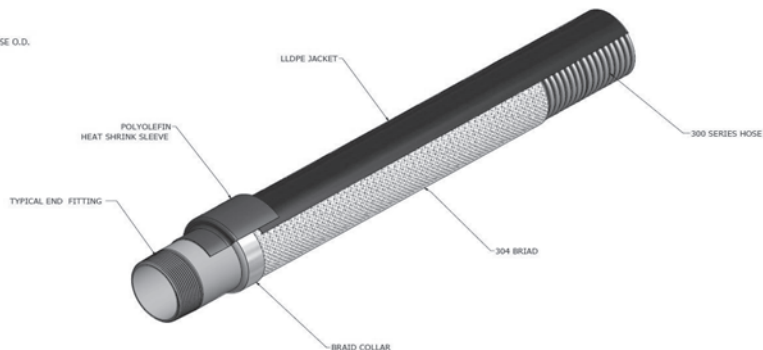

Figure 2 - Typical Hose Assembly with End Fitting

HOSE ASSEMBLIES

by OmegaFlex

- Designed
- Fabricated
- Cleaned
- Tested
- Performance Validated
- Material Certified
- Packaged*

to meet your requirements

CHLORINE TRANSFER HOSE

- Monel 400 hose and braid
- Meets Chlorine Institute specifications
- Fully tested and prepared for shipping

Tough demanding applications such as chlorine transfer require a precision fabricated hose assembly that meets the requirements of The Chlorine Institute Pamphlet 6. OmegaFlex fabricates Chlorine Transfer hoses utilizing Monel 400. Monel 400 has excellent resistance to dry chlorine gas. Hose assemblies are fabricated using a single or double layer of Monel braid. A stainless steel interlock casing is provided to protect the braid from damage. Chlorine Transfer hoses are supplied with fittings of Monel 400 Schedule 80 material in either pipe nipple or with stub ends and steel floating flanges.

When specified, Chlorine Transfer assemblies are tested, cleaned, ends capped, bagged and tagged per The Chlorine Institute requirements.

*Special packaging quoted as an additional charge.

CARGO TRANSFER HOSE

- Large diameters and long overall lengths
- 304, 321 or 316L stainless steel
- Certification to USCG Requirements available

Cargo Transfer Hoses are commonly used to transfer ship to shore media such as chemicals, asphalt and oil products. OmegaFlex's custom hose fabrication department can supply your requirements for Cargo Transfer Hoses. We have the ability to fabricate large diameter hoses such as 6", 8", 10", 12", 14" or even 16" in lengths of 40 feet or more.

When specified, Cargo Transfer Hoses can be fabricated and certified to meet USCG requirements.

FORMEX HOSE

- Unique hose properties
- Easy installation
- Sizes ¼" to 2"

Hose assemblies utilizing OmegaFlex Formex hose allow easy installation even in the most difficult applications. This unique hose design may be bent into intricate patterns prior to installation. The hose will turn corners, bend around obstructions and may be preformed to fit your machinery without ovalizing or compromising its fluid handling capabilities.

Formex hose assemblies are available in 304, 321 or 316L stainless steel materials. The hose is normally provided with a single layer of braid and a wide variety of end fittings are available. If your application requires flexure cycle life or desirable "stay-put" bend characteristics, then OmegaFlex Formex hose may be your problem solver.



JACKETED HOSE

- Keep cryogenic liquids cold
- Increase flow of viscous media
- Safety containment

A Jacketed or Duplex hose assembly is a hose within a hose. Both inner and outer hoses act independently as separate pressure carriers. Vacuum Jacketed hose assemblies are typically found in cryogenic applications because of their insulation properties. Steam Jacketed hose assemblies are utilized when the media is viscous and steam is used to help reduce viscosity and increase flow.

Jacketed hoses are also used in applications where containment of the media is critical in case of rupture of the inner hose. Contact OmegaFlex with your specification and we will engineer a specialty Jacketed Hose assembly for you.

OXYGEN LANCE HOSE

- Large size range available
- Customized to meet critical application requirements
- Cleaned and capped for commercial oxygen service

Critical applications such as supplying commercial oxygen require expertise of an experienced metal hose manufacturer. OmegaFlex Oxygen Lance Hose is fabricated to meet this critical application when specified, our fabrication department can customize the hose assembly, available in sizes through 16", to include a liner (to reduce turbulence resulting from high velocity), reinforced ends, casing or special end fittings. Each hose assembly, is cleaned and capped for commercial oxygen service.

HIGH PRESSURE HOSE

- Engineered designs
- Precision fabrication
- Pressures higher than published ratings

OmegaFlex has the capability to design hose assemblies to meet pressures higher than published ratings. If your requirements exceed published criteria, contact OmegaFlex to determine if a proper hose and braid design can be engineered to meet your specification.

VIBRATION ABSORBERS

- UL recognized for refrigeration applications
- All bronze construction
- Female sweat fittings

OmegaFlex Vibration Absorbers are available to fit copper tubing O.D. sizes from ¼" through 3 ⅝". Construction utilizes copper alloy C51000 (95/5) core and commercial bronze C22000 (90/10) braid. Each Vibration Absorber is precision fabricated, then cleaned, dried and sealed in bags for use in refrigeration and air-conditioning systems. Vapor barrier covers are also available.

Contact OmegaFlex for a copy of the Vibration Absorber brochure.

CHLORINE Hose Assembly

The OmegaFlex® Chlorine Hose Assembly consists of corrugated Monel 400 alloy tubing with Monel 400 one or two layers of braid. End fittings are either schedule 80 Monel NPT or Type A carbon steel Lap Joint flanges with Monel stub ends. 304 stainless steel casing covers the outside of the assembly. The hose assemblies are manufactured in accordance with the Chlorine Institute pamphlet 6 current addition.

Chlorine Hose Assembly Materials

TUBING MATERIAL: Corrugated Monel 400 tubing conforms to ASTM B-127, Monel alloy UNS No. N04400.
BRAID MATERIAL: Monel 400 wire conforms to QQ-N-281 Rev D. Monel alloy UNS No. N04400.
FITTING MATERIAL: Monel 400 schedule 80 pipe conforms to ASTM B-165, Monel alloy UNS No. N04400 or ASTM A-105, ANSI B16.5 Class 300 Carbon Steel Lap Joint Flanges with Monel 400 stub ends conforming to ASTM B-366
CASING MATERIAL: 304L Stainless steel conforms to ASTM A-240, 304L alloy UNS No. S30403
RESOURCES: The Chlorine Institute Pamphlet 6 – Piping for Dry Chlorine
 ISO 10380:2012 Pipework – Corrugated Metal Hoses and Hose Assemblies
 NAHAD 400:2005 – Corrugated Metal Hose Assembly Specification Guidelines

Operational Temperatures

-40°F to 122°F

Chlorine Hose Assembly With Schedule 80 Npt End Fittings

| Item | Description | Material |
|------|----------------------|----------------------|
| 1. | Schedule 80 Pipe NPT | Monel 400 |
| 2. | Wrench Nut | Carbon Steel |
| 3. | Collars | Monel 400 |
| 4. | Chafe Guard | 304L Stainless Steel |
| 5. | 1 or 2 Braid Layers | Monel 400 |
| 6. | Corrugated Tube | Monel 400 |

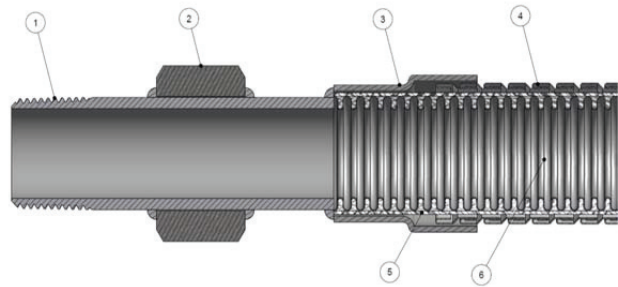

CHLORINE Hose Assembly

Chlorine Hose Assembly With Monel Stub Ends And Carbon Steel Flanges:

| Item | Description | Material |
|------|-----------------------------|----------------------|
| 1. | 300# Lap Joint Flange | Carbon Steel |
| 2. | Schedule 80 Type A Stub End | Monel 400 |
| 3. | Collars | Monel 400 |
| 4. | Chafe Guard | 304L Stainless Steel |
| 5. | 1 or 2 Braid Layers | Monel 400 |
| 6. | Corrugated Tube | Monel 400 |

ed Monel 400 alloy tubing with Monel 400 one or NPT or Type A carbon steel Lap Joint flanges with side of the assembly. The hose assemblies are inlet 6 current addition.

to ASTM B-127, Monel alloy UNS No. N04400. Rev D. Monel alloy UNS No. N04400.

to ASTM B-165, Monel alloy UNS No. N04400 or Carbon Steel Lap Joint Flanges with Monel 400 stub

Specifications — Pressure ratings at 70°F (PSIG)

| Size (NON) | Corrugated Tubing ID (NOM) | Casing OD (in.) 1B / 2B | Max Working Pressure 1B / 2B | Max Test Pressure 1B / 2B | Nominal Burst 1B / 2B |
|------------|----------------------------|-------------------------|------------------------------|---------------------------|-----------------------|
| ½ | 0.550 | 1.000 1.130 | 681 1,077 | 1,362 2,154 | 3,406 5,385 |
| ¾ | 0.800 | 1.260 1.380 | 567 929 | 1,134 1,858 | 2,835 4,643 |
| 1 | 1.025 | 1.650 1.780 | 554 907 | 1,108 1,814 | 2,769 4,533 |
| 1¼ | 1.242 | 2.030 2.160 | 489 792 | 978 1,584 | 2,445 3,962 |
| 1½ | 1.563 | — 2.530 | — 615 | — 1,230 | — 3,075 |
| 2 | 1.992 | — 3.030 | — 493 | — 986 | — 2,463 |

Chlorine Institute Pamphlet 6 Hose Assembly

- Hydrostatic tested at 2 times the MAWP
- Commercial oven dried to ensure moisture is removed
- Weld inspection with Helium Mass Spectrometer at a leak rate of 1×10^{-9}
- Yearly samples tested at 5 times the MAWP and 2 times 15% deformation
- Manufactured to ISO 10380 bending requirements
- Procedures and Welder Qualifications in accordance with ANSI/ASME BPV-IX AND ASME B31.3
- Packaged, tagged, and all documentation per specification
- Material verified using a calibrated handheld X-ray Fluorescence Analyzer (PMI)

Hose Assembly DESIGN CRITERIA

TERMINOLOGY

Abrasion/Erosion

Internal abrasion is the wearing away of the inside corrugations of the hose caused by the flow of the media conveyed such as wet steam or abrasive particles. External abrasion is the damage to the hose assembly caused by being rubbed on a foreign object.

Ambient Conditions

Surrounding conditions such as pressure, corrosion or temperature to which the hose assembly is exposed.

Amplitude of Vibration

The distance a hose assembly deflects laterally to one side from its installed position.

Angular Offset

The bending of the hose so that the ends are no longer parallel. Amount of movement is measured in degrees from centerline of the hose.

Annular Corrugation

Convolutions on a hose that are a series of complete circles or rings located at right angles to the longitudinal axis of the hose.

Armor/Casing

Flexible interlocked tubing placed over the entire length or in short lengths at the end of a metal hose to protect it from physical damage and/or to limit the bending radius.

Attachment

The method of fixing end fittings to flexible metal hose, i.e. welding, brazing, soldering, swaging, bonding or mechanical.

Axial Motion

Compression or extension movement along the longitudinal axis of the pipeline.

Basket Weave Braid

Strands of wire are alternately crossed two over and two under.

Bend Radius

The radius of a hose measured at the hose centerline.

Braid

Metal wire braid on a hose assembly permits the hose assembly a higher pressure capability by acting as a restraint against hose elongation and acts to dampen vibrations. A second layer of braid may be used to increase pressure ratings provided the test pressure does not result in permanent corrugation deformation. Other design considerations may result in the use of a heavy braid to increase abrasion resistance characteristics.

Braid Angle

Angle formed by the braid strands and the longitudinal axis of the hose.

Braid Coverage

Optimal braid coverage is engineered to contain the core and reduce the possibility of squirm. Properly designed braid coverage will balance pressure capability with flexing requirements. Minimization of braid wear on the crown of the corrugation is also provided by optimal braid coverage.

Braid Sleeve/Ferrule

The Braid Sleeve or Ferrule is used to isolate the end of the corrugated hose and braid from flexure. The core and braid are welded to the braid sleeve or ferrule during fabrication of the hose assembly.

Braid Wear

Motion between the braid and corrugated hose normally causes wear on the crown or OD of the corrugation and the inside diameter of the braid.

Braided Braid

Braided braid is manufactured the same as tubular braid except that wires in the strand are braided together prior to the manufacture of the braid. Braided braid is primarily used on larger diameter hose assemblies.

Brazing

A process of joining metals using a non-ferrous filler metal having a melting point that is lower than the parent metals to be joined.

Casing

Same as Armor.

Constant Flexing

Regular cyclic motion at a slow cyclic rate and constant travel. The dynamic minimum centerline bend radius must be doubled on constant flexing applications.

Corrosion

The chemical or electro-chemical attack of a media upon a hose assembly.

Corrugation/Convolution

Annular or helical flexing member in corrugated metal hose.

Cycle Life

The number of cycles a hose is flexed before failure.

Cycle Motion

Movement from neutral to extreme position and then returning to the neutral position.

Deflection Force, Lateral

Force to laterally deflect the hose assembly a specific distance from the neutral position with one end fixed and the other end in motion.

Developed Length

Overall length of the hose assembly, including the fittings, that is required to meet the conditions of a specific application.

Diamond Weave Braid

Strands of wire alternately cross one over and one under.

Dog-Leg Assembly

Two hose assemblies joined by a common elbow to permit movement in multiple planes.

Dye Penetrant Test

Non-destructive test method for detecting surface defects.

Dynamic Motion

Non-continuous or intermittent controlled motion such as the result of thermal expansion.

Duplex Hose Assembly

Jacketed or Duplex hose assembly is a hose within a hose. Both inner and outer hoses act independently as separate pressure carriers.

Effective Thrust Area

Cross-sectional area defined by the mean diameter of the hose.

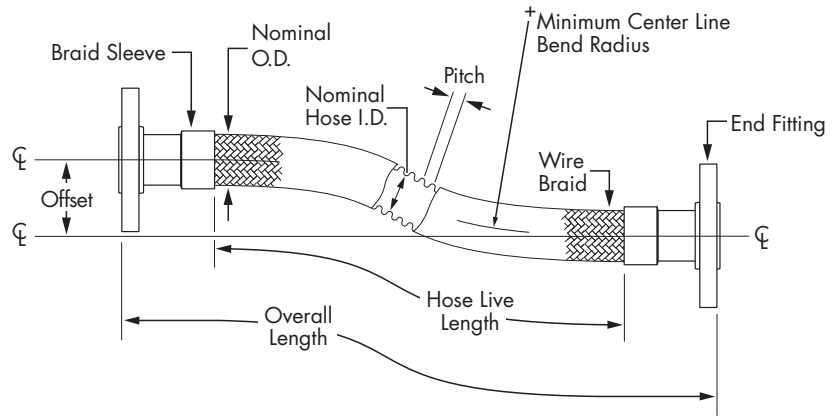

Fatigue

Damage of the hose assembly due to excessive flexing of the corrugations.

Flow Rate

Volume of media being conveyed in a specific time period such as gallons per minute, cubic feet per second or pounds per hour.

Frequency of Vibration

The rate of vibration or flexure of a hose in a given time period such as cycles per second (CPS), cycles per minute (CPM) or cycles per day (CPD).

Galvanic Corrosion

Corrosion that occurs on the less noble of two dissimilar metals in direct contact with each other in an electrolyte such as water, sulfuric acid or sodium chloride solution.

Helical Corrugation

Hose corrugation formed in tubing to resemble a continuous spiral or screw thread.

Helical Wire Armor/Spring Guard

Used to provide additional protection against abrasion. Metal hoses can be supplied with an external round or oval section wire spiral.

Inside Diameter (ID)

The diameter inside of the hose corrugation measured at the closest point either side of centerline of the hose.

Intermittent Flexure

Non-continuous or intermittent controlled motion such as the result of thermal expansion.

ISO 10380

A standard developed by ISO (International Standards Organization) that helps define the industry requirements for design, manufacture and testing of corrugated metal hose and hose assemblies.

TERMINOLOGY (Continued)

Lateral Offset

This motion occurs when the hose centerline is moved in a plane perpendicular to the longitudinal axis with the end remaining parallel.

Liner

Flexible sleeve used to protect the internal side of the corrugation when conveying a high velocity media, also helps to reduce internal abrasion.

Live Length

The amount of active or flexible length of hose in an assembly. Does not include the length of fittings and braid sleeves/ferrules.

Loop Installation

The assembly is installed in a loop or U shape and is most often used when frequent and/or large amounts of motion are involved.

Media

The substance(s) transferred through a system.

Minimum Bend Radius

The smallest radius to which a hose can be bent without permanent deformation of the corrugations.

Nominal Hose Size

Indicates the approximate inside diameter of the hose.

Operating Conditions

The pressure, temperature, motion and environment to which a hose assembly is subjected.

Outside Diameter (OD)

The external diameter of a metal hose measured at the top of the corrugation or braiding.

Penetration (Weld)

The percentage of wall thickness of the two parts to be joined that is fused into the weld pool in making a joint.

Permanent Bend/Static Bend

A fixed radius bend in a hose assembly used to compensate for misalignment.

Pitch

The distance between the two peaks of adjacent corrugation or convolution.

Ply/Plies

The number of individual thicknesses of metal used in the construction of a wall of the convoluted hose.

Pressure

Usually expressed in pounds per square inch gauge or psig.

Pressure, Absolute

A total pressure measurement system in which atmospheric pressure at sea level is added to the gauge pressure and expressed as psia.

Pressure, Atmospheric

The pressure of the atmosphere at sea level which is 14.7 psig or 29.92 inches of mercury.

Pressure, Burst (Actual)

Amount of pressure determined through testing required to cause a rupture in the hose wall.

Pressure, Burst (Nominal)

The average amount of pressure, at ambient temperature, at which the core or braid can be expected to rupture.

Pressure, Deformation

The pressure at which the convolutions of a hose become permanently deformed.

Pressure, Feet of Water or Head

Often used to express system pressure in terms of water column height. A column of water 1 foot high exerts a .434 psi at its base.

Pressure, Maximum Working

Maximum pressure that the hose should be subjected to on a continuous basis.

Pressure, Maximum Test

Maximum pressure the hose should be subjected to during proof pressure testing without permanently deforming the corrugations.

Pressure, Pulsating

A rapid change in the pressure above and below the normal base pressure usually associated with reciprocating type pumps. Pulsating pressure can cause excessive wear between the braid and the top or crown of the hose corrugation.

Pressure, Shock

A sudden increase of pressure in a hydraulic or pneumatic system that produces a shock wave. This shock can cause severe permanent deformation of the corrugations in a hose as well as rapid damage of the assembly due to metal fatigue.



Pressure, Static

A non-changing constant pressure.

Pressure, Working

The internal or external pressure imposed on a hose during operating conditions.

psia

Pounds per square inch absolute.

psig

Pounds per square inch gauge.

Radial Motion

The type of movement that occurs when hoses are bent in a 180° arc such as in vertical or horizontal traveling loops.

Random Motion

The uncontrolled motion of a metal hose such as motion that occurs during manual handling.

Reinforced End

A short interlocked casing or spring guard used to restrict bending at the end of the hose.

Safety Factor

The relationship or ratio of maximum working pressure to nominal burst pressure.

Scale

An oxide or thin coating of media in/on a hose assembly brought about by surface conditions or welding.

Seamless

Used in reference to corrugated metal hose that is made from a base tube that does not have a longitudinal weld seam.

Segment/Splice

A method of joining two sections of hose.

Squirm

Damage to the hose when it is deformed into an "S" or "U" bend as the result of excessive internal pressure being applied to unbraided corrugated hose while its ends are restrained, or in a braided corrugated hose that has been axially compressed.

Static Bend

A fixed radius bend in a hose assembly used to compensate for misalignment.

Strand

Individual groups of wire in a braid.

Stress Corrosion

A form of corrosion in stainless steel normally associated with chlorides.

Temperature Correction Factor

The factor that corrects the pressure rating in elevated temperature applications.

Tig Weld/GTAW

The tungsten inert gas welding process sometimes referred to as a shielded arc. Common trade name is heliarc.

Traveling Loop

General classification of bending wherein the hose is installed to a U-shaped configuration.

Traveling Loop, Class A Loop

An application wherein the radius remains constant and one end of the hose moves parallel to the other end.

Traveling Loop, Class B Loop

A condition wherein a hose is installed in a U-shaped configuration and the ends move perpendicular to each other so as to enlarge or decrease the width of the loop.

Torque/Torsion

A force that produces or tends to produce rotation of or torsion about the longitudinal axis of a hose assembly while the other end is fixed.

Vacuum

Negative pressure or suction usually expressed as inches of mercury.

Velocity

The speed at which the medium flows through the hose.

Velocity Resonance

Vibration of corrugations due to the buffeting of a high velocity gas or liquid flow.

Vibration

Low amplitude motion occurring at high frequency.

Welding

The process of localized joining of two or more metallic components by means of heating their surfaces to a state of fusion or by fusion with the use of additional filler material.

MOTION

Hose Live Length

The live length of the hose assembly must be sufficient in order for the hose to properly meet the movement requirements. A hose assembly with a live length shorter than suggested could cause premature failure.

Lateral Offset Motion

This motion occurs when the hose centerline is moved in a plane perpendicular to the longitudinal axis with the end remaining parallel. Dynamic offset motion should never be more than 25% of the minimum centerline bend radius. See page 24 for design information on lateral offset.

Angular Offset Motion

Angular movement is defined as the bending of the hose so that the ends are no longer parallel. Amount of movement is measured in degrees from centerline of the hose if were installed straight. See page 23 for design information on angular offset.

Axial Movement

Axial movement is compression or elongation along the longitudinal axis. Metal hose assemblies installed in line with the longitudinal axis of the piping should not be subjected to axial movement.

Two design options are available to compensate for axial movement. The first option is installation of the metal hose assembly perpendicular to the longitudinal axis of the pipeline. As axial movement occurs, the metal hose assembly will be subjected to lateral offset. See page 24 for additional design information.

The second option is the use of a Class "B" traveling loop. See page 22 for design requirements of traveling loops.

Torsion Movement

Torsion movement occurs when the hose is twisted or torqued such as when the hose bends out of plane or during improper installation.

Twisting forces are extremely destructive and are one of the most common causes for premature failure.

Motion Frequency

The rate of flexure that the hose is subjected to in a given time period. Three basic types of motion frequency include vibration, dynamic motion and continuous motion.

Vibration

This is low amplitude motion occurring at high frequency. Vibration is normally found in engine exhaust, pump and compressor applications. Hose resonance must be avoided to prevent premature failure. Consult OmegaFlex engineering if hose resonance is anticipated or for additional vibration data.

Dynamic/Intermittent Motion

Non-continuous or intermittent motion such as the result of thermal expansion. Dynamic bend radius is used in calculations determining the hose live length for lateral offset, angular offset and radial motion during dynamic or intermittent flexing.

Static Bend

A non-moving or fixed radius bend in a hose assembly used to compensate for misalignment.

Continuous Motion

Regular cyclic motion at a slow cyclic rate and constant travel. The dynamic minimum centerline bend radius must be doubled on continuous motion applications.

Random Motion

The uncontrolled motion of a metal hose such as motion that occurs during manual handling.

Bend Radius

The minimum radius the hose can be bent and still maintain the integrity of the hose. Usually expressed as dynamic or static centerline bend radius. The bend radius is used in calculations associated with angular and lateral offset motion.

Cycle Life

The number of cycles a hose is flexed before failure. Some factors that affect cycle life include working pressure, temperature, bend radius, hose and braid materials. OmegaFlex uses the ISO10380 fatigue test standard for cycle life testing. See page 2 for a more complete description of the ISO 10380 standard.

Radial Movement

This type of movement occurs when hoses are bent in a 180° arc such as in vertical or horizontal traveling loops. Traveling loops are classified a Class “A” where the bend radius remains constant and the one end of the hose moves parallel to the other end.

A Class “B” traveling loop has the hose installed in a U-shaped configuration and the ends move perpendicular to each other so as to enlarge or decrease the width of the loop.

Horizontal travelling loops must have the bottom leg of the hose supported to avoid undue stress on the end of the hose. The weight of the hose and media inside the hose will reduce the pressure capability of the hose. Weight loads should be considered when engineering corrugated metal hose assemblies for travelling loop applications.

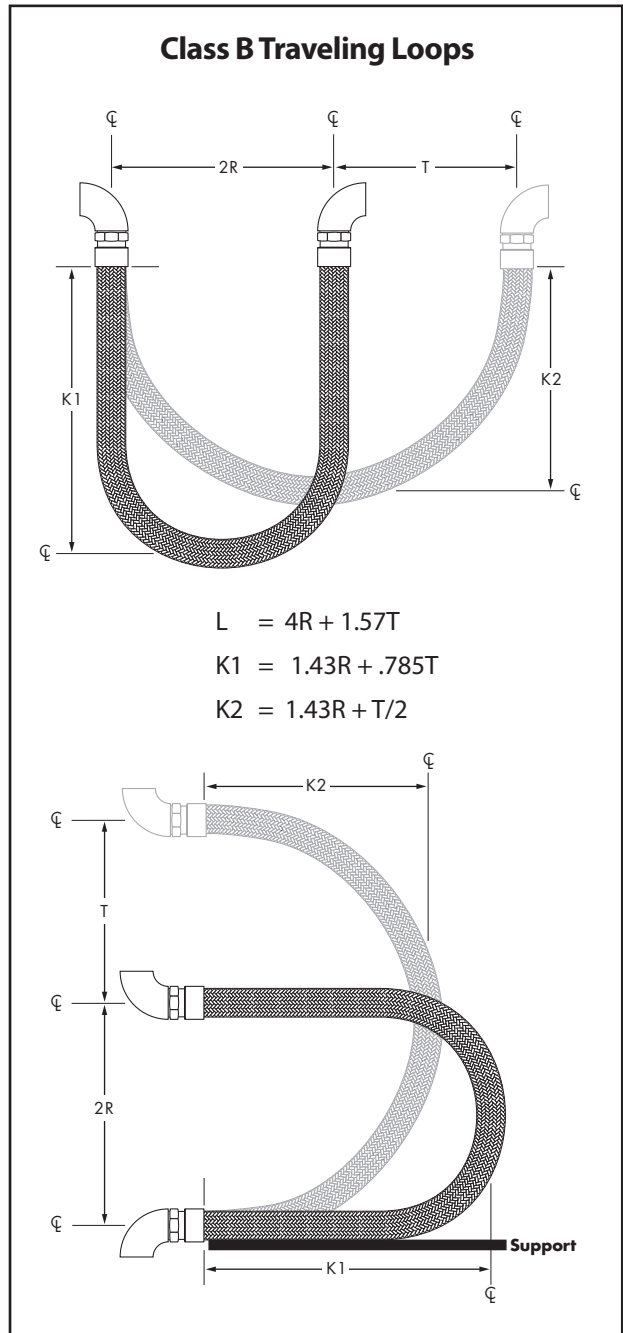
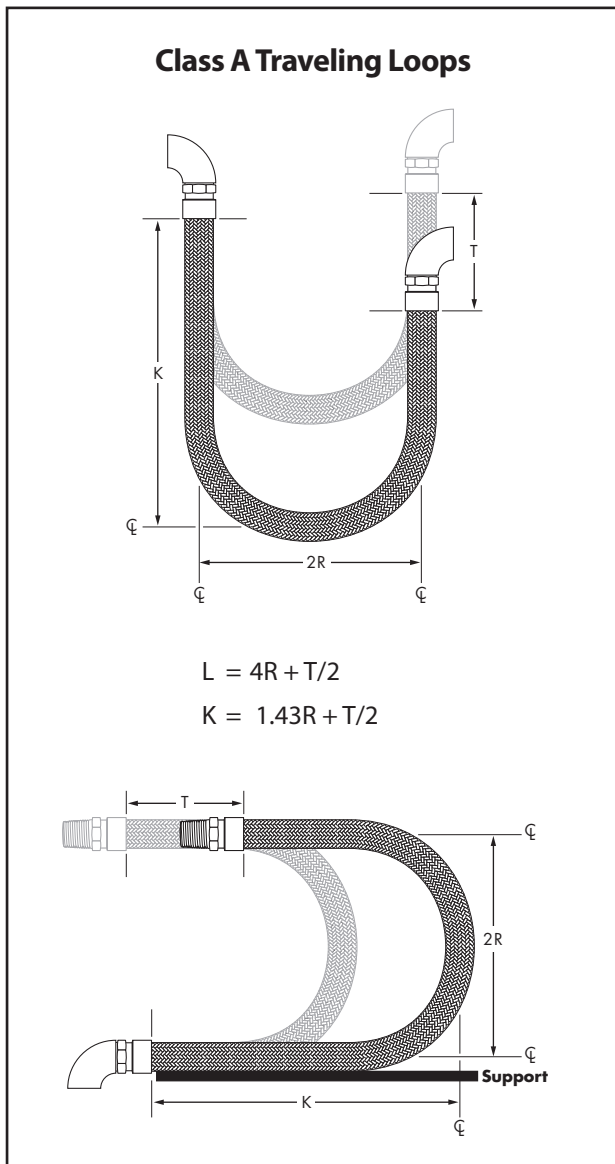

- T = Total travel (inches)
- R = Centerline bend radius (inches)
- L = Hose live length (inches)
- K = Loop length (inches)

MOTION (Continued)

Angular Offset Motion

Angular movement is defined as the bending of the hose so that the ends are no longer parallel. Amount of movement is measured in degrees from centerline of the hose if were installed straight.

Minimum Live Length of Hose For Angular Offset Motion

| | | Degree of Angular Motion = θ | | | | | | | | | | | | | |
|----------------------------------|------|-------------------------------------|------|------|------|------|------|-------|-------|-------|-------|-------|-------|-------|------|
| | | 10 | 15 | 20 | 25 | 30 | 40 | 50 | 60 | 70 | 80 | 90 | 120 | 150 | 180 |
| Centerline Bend Radius (in.) = R | 2 | 0.4 | 0.6 | 0.7 | 0.9 | 1.1 | 1.4 | 1.8 | 2.1 | 2.5 | 2.8 | 3.2 | 4.2 | 5.3 | 6.3 |
| | 3 | 0.6 | 0.8 | 1.1 | 1.4 | 1.6 | 2.1 | 2.7 | 3.2 | 3.7 | 4.2 | 4.8 | 6.3 | 7.9 | 9.5 |
| | 4 | 0.7 | 1.1 | 1.4 | 1.8 | 2.1 | 2.8 | 3.5 | 4.2 | 4.9 | 5.6 | 6.3 | 8.4 | 10.5 | 12.6 |
| | 5 | 0.9 | 1.4 | 1.8 | 2.2 | 2.7 | 3.5 | 4.4 | 5.3 | 6.2 | 7.0 | 7.9 | 10.5 | 13.1 | 15.8 |
| | 6 | 1.1 | 1.6 | 2.1 | 2.7 | 3.2 | 4.2 | 5.3 | 6.3 | 7.4 | 8.4 | 9.5 | 12.6 | 15.8 | 18.9 |
| | 7 | 1.3 | 1.9 | 2.5 | 3.1 | 3.7 | 4.9 | 6.2 | 7.4 | 8.6 | 9.8 | 11.0 | 14.7 | 18.4 | 22.0 |
| | 8 | 1.4 | 2.1 | 2.8 | 3.5 | 4.2 | 5.6 | 7.0 | 8.4 | 9.8 | 11.2 | 12.6 | 16.8 | 21.0 | 25.2 |
| | 9 | 1.6 | 2.4 | 3.2 | 4.0 | 4.8 | 6.3 | 7.9 | 9.5 | 11.0 | 12.6 | 14.2 | 18.9 | 23.6 | 28.3 |
| | 10 | 1.8 | 2.7 | 3.5 | 4.4 | 5.3 | 7.0 | 8.8 | 10.5 | 12.3 | 14.0 | 15.8 | 21.0 | 26.2 | 31.5 |
| | 11 | 2.0 | 2.9 | 3.9 | 4.8 | 5.8 | 7.7 | 9.6 | 11.6 | 13.5 | 15.4 | 17.3 | 23.1 | 28.8 | 34.6 |
| | 12 | 2.1 | 3.2 | 4.2 | 5.3 | 6.3 | 8.4 | 10.5 | 12.6 | 14.7 | 16.8 | 18.9 | 25.2 | 31.5 | 37.7 |
| | 13 | 2.3 | 3.5 | 4.6 | 5.7 | 6.9 | 9.1 | 11.4 | 13.7 | 15.9 | 18.2 | 20.5 | 27.3 | 34.1 | 40.9 |
| | 14 | 2.5 | 3.7 | 4.9 | 6.2 | 7.4 | 9.8 | 12.3 | 14.7 | 17.2 | 19.6 | 22.0 | 29.4 | 36.7 | 44.0 |
| | 15 | 2.7 | 4.0 | 5.3 | 6.6 | 7.9 | 10.5 | 13.1 | 15.8 | 18.4 | 21.0 | 23.6 | 31.5 | 39.3 | 47.2 |
| | 16 | 2.8 | 4.2 | 5.6 | 7.0 | 8.4 | 11.2 | 14.0 | 16.8 | 19.6 | 22.4 | 25.2 | 33.6 | 41.9 | 50.3 |
| | 17 | 3.0 | 4.5 | 6.0 | 7.5 | 9.0 | 11.9 | 14.9 | 17.9 | 20.8 | 23.8 | 26.8 | 35.7 | 44.6 | 53.5 |
| | 18 | 3.2 | 4.8 | 6.3 | 7.9 | 9.5 | 12.6 | 15.8 | 18.9 | 22.0 | 25.2 | 28.3 | 37.7 | 47.2 | 56.6 |
| | 19 | 3.4 | 5.0 | 6.7 | 8.3 | 10.0 | 13.3 | 16.6 | 19.9 | 23.3 | 26.6 | 29.9 | 39.8 | 49.8 | 59.7 |
| | 20 | 3.5 | 5.3 | 7.0 | 8.8 | 10.5 | 14.0 | 17.5 | 21.0 | 24.5 | 28.0 | 31.5 | 41.9 | 52.4 | 62.9 |
| 22 | 3.9 | 5.8 | 7.7 | 9.6 | 11.6 | 15.4 | 19.2 | 23.1 | 26.9 | 30.8 | 34.6 | 46.1 | 57.6 | 69.2 | |
| 24 | 4.2 | 6.3 | 8.4 | 10.5 | 12.6 | 16.8 | 21.0 | 25.2 | 29.4 | 33.6 | 37.7 | 50.3 | 62.9 | 75.4 | |
| 26 | 4.6 | 6.9 | 9.1 | 11.4 | 13.7 | 18.2 | 22.7 | 27.3 | 31.8 | 36.4 | 40.9 | 54.5 | 68.1 | 81.7 | |
| 28 | 4.9 | 7.4 | 9.8 | 12.3 | 14.7 | 19.6 | 24.5 | 29.4 | 34.3 | 39.1 | 44.0 | 58.7 | 73.4 | 88.0 | |
| 30 | 5.3 | 7.9 | 10.5 | 13.1 | 15.8 | 21.0 | 26.2 | 31.5 | 36.7 | 41.9 | 47.2 | 62.9 | 78.6 | 94.3 | |
| 35 | 6.2 | 9.2 | 12.3 | 15.3 | 18.4 | 24.5 | 30.6 | 36.7 | 42.8 | 48.9 | 55.0 | 73.4 | 91.7 | 110.0 | |
| 40 | 7.0 | 10.5 | 14.0 | 17.5 | 21.0 | 28.0 | 35.0 | 41.9 | 48.9 | 55.9 | 62.9 | 83.8 | 104.8 | 125.7 | |
| 45 | 7.9 | 11.8 | 15.8 | 19.7 | 23.6 | 31.5 | 39.3 | 47.2 | 55.0 | 62.9 | 70.7 | 94.3 | 117.9 | 141.4 | |
| 50 | 8.8 | 13.1 | 17.5 | 21.9 | 26.2 | 35.0 | 43.7 | 52.4 | 61.1 | 69.9 | 78.6 | 104.8 | 130.9 | 157.1 | |
| 60 | 10.5 | 15.8 | 21.0 | 26.2 | 31.5 | 41.9 | 52.4 | 62.9 | 73.4 | 83.8 | 94.3 | 125.7 | 157.1 | 188.5 | |
| 70 | 12.3 | 18.4 | 24.5 | 30.6 | 36.7 | 48.9 | 61.1 | 73.4 | 85.6 | 97.8 | 110.0 | 146.7 | 183.3 | 220.0 | |
| 80 | 14.0 | 21.0 | 28.0 | 35.0 | 41.9 | 55.9 | 69.9 | 83.8 | 97.8 | 111.8 | 125.7 | 167.6 | 209.5 | 251.4 | |
| 90 | 15.8 | 23.6 | 31.5 | 39.3 | 47.2 | 62.9 | 78.6 | 94.3 | 110.0 | 125.7 | 141.4 | 188.5 | 235.7 | 282.8 | |
| 100 | 17.5 | 26.2 | 35.0 | 43.7 | 52.4 | 69.9 | 87.3 | 104.8 | 122.2 | 139.7 | 157.1 | 209.5 | 261.8 | 314.2 | |

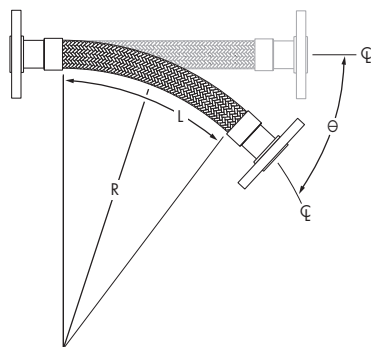

$$\text{Formula: } L = \frac{\pi R \theta}{180}$$

L = Live hose length (inches)

$\pi = 3.1416$

R = Minimum centerline bend radius for constant flexing (inches)

θ = Angular deflection (degrees)

Lateral Offset Motion

This motion occurs when the hose centerline is moved in a plane perpendicular to the longitudinal axis with the end remaining parallel. **Dynamic offset motion should never be more than 25% of the minimum centerline bend radius.**

Minimum Live Length of Hose For Lateral Offset Motion

| | Dynamic Lateral Offset Motion (in.) = T | | | | | | | | | | | | | |
|-----|---|------|------|------|------|------|-------|------|------|------|------|------|------|------|
| | 1/8 | 1/4 | 3/8 | 1/2 | 3/4 | 1 | 1 1/2 | 2 | 3 | 4 | 5 | 6 | 8 | 10 |
| 2 | 1.3 | 1.8 | 2.2 | 2.5 | 3.1 | 3.7 | 4.5 | 5.3 | 6.8 | 8.0 | 9.3 | 10.4 | 12.7 | 14.9 |
| 3 | 1.6 | 2.2 | 2.7 | 3.1 | 3.8 | 4.4 | 5.5 | 6.4 | 8.0 | 9.4 | 10.8 | 12.0 | 14.5 | 16.8 |
| 4 | 1.8 | 2.5 | 3.1 | 3.5 | 4.4 | 5.0 | 6.2 | 7.3 | 9.0 | 10.6 | 12.1 | 13.5 | 16.0 | 18.5 |
| 5 | 2.0 | 2.8 | 3.4 | 4.0 | 4.9 | 5.6 | 6.9 | 8.0 | 10.0 | 11.7 | 13.3 | 14.7 | 17.5 | 20.0 |
| 6 | 2.2 | 3.1 | 3.7 | 4.3 | 5.3 | 6.1 | 7.5 | 8.8 | 10.9 | 12.7 | 14.4 | 15.9 | 18.8 | 21.5 |
| 7 | 2.3 | 3.3 | 4.0 | 4.7 | 5.7 | 6.6 | 8.1 | 9.4 | 11.7 | 13.6 | 15.4 | 17.0 | 20.0 | 22.9 |
| 8 | 2.5 | 3.5 | 4.3 | 5.0 | 6.1 | 7.0 | 8.7 | 10.0 | 12.4 | 14.5 | 16.3 | 18.0 | 21.2 | 24.1 |
| 9 | 2.7 | 3.7 | 4.6 | 5.3 | 6.5 | 7.5 | 9.2 | 10.6 | 13.1 | 15.3 | 17.2 | 19.0 | 22.3 | 25.3 |
| 10 | 2.8 | 3.9 | 4.8 | 5.5 | 6.8 | 7.9 | 9.7 | 11.2 | 13.8 | 16.0 | 18.1 | 19.9 | 23.4 | 26.5 |
| 11 | 2.9 | 4.1 | 5.0 | 5.8 | 7.1 | 8.2 | 10.1 | 11.7 | 14.4 | 16.8 | 18.9 | 20.8 | 24.4 | 27.6 |
| 12 | 3.1 | 4.3 | 5.3 | 6.1 | 7.4 | 8.6 | 10.5 | 12.2 | 15.0 | 17.5 | 19.7 | 21.7 | 25.3 | 28.7 |
| 13 | 3.2 | 4.5 | 5.5 | 6.3 | 7.7 | 8.9 | 11.0 | 12.7 | 15.6 | 18.2 | 20.4 | 22.5 | 26.3 | 29.7 |
| 14 | 3.3 | 4.6 | 5.7 | 6.5 | 8.0 | 9.3 | 11.4 | 13.2 | 16.2 | 18.8 | 21.1 | 23.3 | 27.2 | 30.7 |
| 15 | 3.4 | 4.8 | 5.9 | 6.8 | 8.3 | 9.6 | 11.8 | 13.6 | 16.8 | 19.4 | 21.8 | 24.0 | 28.0 | 31.7 |
| 16 | 3.5 | 5.0 | 6.1 | 7.0 | 8.6 | 9.9 | 12.1 | 14.0 | 17.3 | 20.0 | 22.5 | 24.8 | 28.9 | 32.6 |
| 17 | 3.6 | 5.1 | 6.2 | 7.2 | 8.8 | 10.2 | 12.5 | 14.5 | 17.8 | 20.6 | 23.2 | 25.5 | 29.7 | 33.5 |
| 18 | 3.7 | 5.3 | 6.4 | 7.4 | 9.1 | 10.5 | 12.9 | 14.9 | 18.3 | 21.2 | 23.8 | 26.2 | 30.5 | 34.4 |
| 19 | 3.8 | 5.4 | 6.6 | 7.6 | 9.3 | 10.8 | 13.2 | 15.3 | 18.8 | 21.8 | 24.4 | 26.9 | 31.3 | 35.3 |
| 20 | 3.9 | 5.5 | 6.8 | 7.8 | 9.6 | 11.0 | 13.5 | 15.7 | 19.3 | 22.3 | 25.0 | 27.5 | 32.0 | 36.1 |
| 22 | 4.1 | 5.8 | 7.1 | 8.2 | 10.0 | 11.6 | 14.2 | 16.4 | 20.2 | 23.4 | 26.2 | 28.8 | 33.5 | 37.7 |
| 24 | 4.3 | 6.1 | 7.4 | 8.5 | 10.5 | 12.1 | 14.8 | 17.1 | 21.0 | 24.4 | 27.3 | 30.0 | 34.9 | 39.3 |
| 26 | 4.5 | 6.3 | 7.7 | 8.9 | 10.9 | 12.6 | 15.4 | 17.8 | 21.9 | 25.3 | 28.4 | 31.2 | 36.3 | 40.8 |
| 28 | 4.6 | 6.5 | 8.0 | 9.2 | 11.3 | 13.0 | 16.0 | 18.5 | 22.7 | 26.3 | 29.5 | 32.4 | 37.6 | 42.2 |
| 30 | 4.8 | 6.8 | 8.3 | 9.5 | 11.7 | 13.5 | 16.5 | 19.1 | 23.5 | 27.2 | 30.5 | 33.5 | 38.8 | 43.6 |
| 35 | 5.2 | 7.3 | 8.9 | 10.3 | 12.6 | 14.6 | 17.9 | 20.6 | 25.3 | 29.3 | 32.8 | 36.0 | 41.8 | 47.0 |
| 40 | 5.5 | 7.8 | 9.5 | 11.0 | 13.5 | 15.6 | 19.1 | 22.0 | 27.0 | 31.3 | 35.0 | 38.5 | 44.6 | 50.0 |
| 45 | 5.9 | 8.3 | 10.1 | 11.7 | 14.3 | 16.5 | 20.2 | 23.4 | 28.7 | 33.2 | 37.1 | 40.7 | 47.2 | 53.0 |
| 50 | 6.2 | 8.7 | 10.7 | 12.3 | 15.1 | 17.4 | 21.3 | 24.6 | 30.2 | 34.9 | 39.1 | 42.9 | 49.7 | 55.7 |
| 60 | 6.8 | 9.5 | 11.7 | 13.5 | 16.5 | 19.0 | 23.3 | 27.0 | 33.0 | 38.2 | 42.8 | 46.9 | 54.3 | 60.9 |
| 70 | 7.3 | 10.3 | 12.6 | 14.5 | 17.8 | 20.6 | 25.2 | 29.1 | 35.7 | 41.2 | 46.1 | 50.6 | 58.6 | 65.6 |
| 80 | 7.8 | 11.0 | 13.5 | 15.5 | 19.0 | 22.0 | 26.9 | 31.1 | 38.1 | 44.0 | 49.3 | 54.0 | 62.5 | 70.0 |
| 90 | 8.3 | 11.7 | 14.3 | 16.5 | 20.2 | 23.3 | 28.5 | 33.0 | 40.4 | 46.7 | 52.3 | 57.3 | 66.3 | 74.2 |
| 100 | 8.7 | 12.3 | 15.1 | 17.4 | 21.3 | 24.6 | 30.1 | 34.7 | 42.6 | 49.2 | 55.0 | 60.3 | 69.8 | 78.2 |

- a. The offset distance (T) for dynamic flexing should never exceed 25% of the centerline bend radius (R).
- b. The shaded area of this chart may be used only for static offset applications.
- c. When the offset motion occurs to both sides of the hose centerline, use total travel in the formula below; i.e. 2 times (T).
- d. If the difference between (L) and (Lp) is significant, exercise care during installation to avoid stress on hose and braid at the maximum offset distance.

Formula: $L = \sqrt{6RT + T^2}$

$L_p = \sqrt{L^2 - T^2}$

$T_m = \sqrt{9R^2 + L^2} - 3R$

- L = Live hose length (inches)
- Lp = Projected live hose length (inches)
- R = Minimum centerline bend radius (inches)
- T = Offset motion to one side of centerline (inches)
- Tm = Maximum centerline offset for a given L and R

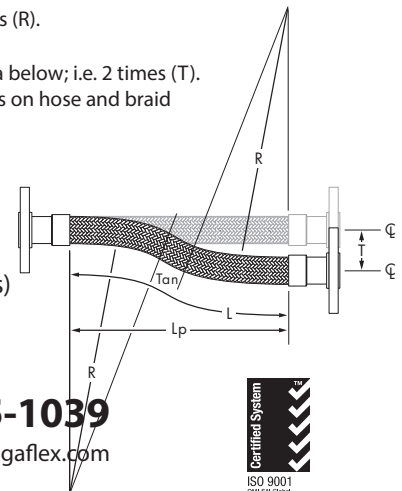

PRESSURE

Maximum Rated Working Pressure

The maximum pressure that the hose should be subjected to on a continuous basis. OmegaFlex establishes this rating by multiplying the nominal rated burst pressure by 25%. Published pressure is calculated at 70°F.

Maximum Rated Test Pressure

The maximum pressure the hose should be subjected to during proof pressure or system testing. Hose corrugation deformation will occur if the maximum rated test pressure is exceeded. The maximum rated working pressure is multiplied by 150% to determine the maximum rated test pressure.

Nominal Rated Burst Pressure

The average pressure at which the core or braid will rupture at ambient temperature. Proper hose assembly fabrication techniques must be used to ensure the hose will meet OmegaFlex published pressures.

Pulsating or Shock Pressure

The performance of metal hose can be greatly reduced under this type of working pressure. Pressures are normally reduced by 50% in pulsating or shock pressure applications. Contact OmegaFlex for additional information on this application.

Pressure/Temperature Correction

Metal hose pressure capabilities decrease as the temperature increases. Consult the temperature correction factor table on page 28 to determine pressure rating at elevated temperatures.

Safety Factors

The maximum working pressure should not be greater than 25% of the nominal rated burst pressure after correcting for the application temperature. The safety factor is generally expressed as a ratio of 4:1.

Pressure Drop

Pressure drop occurs in long hose runs. The charts on page 35 list pressure drop in 100 feet of hose. Contact OmegaFlex if more information is required.

FLOW VELOCITY

Liners

Liquid or gas applications conveying media at high velocity should incorporate an interlock liner in the hose assembly design. The liner will decrease the turbulence caused by the high velocity and reduce the resonant vibration that may occur. A liner is recommended if the velocity is greater than the following:

| Media | Hose Alignment | Maximum Velocity without Liner (ft./sec.) |
|--------|----------------|---|
| liquid | straight | 75 |
| liquid | 45° bend | 56 |
| liquid | 90° bend | 37 |
| gas | straight | 150 |
| gas | 45° bend | 112 |
| gas | 90° bend | 75 |

Conversion Formulas

| Definitions ^a | Feet Per Second (ft./sec.) |
|----------------------------|---|
| gph: gallons per hour | $(\text{gph} \div \text{ID}^2) \times 0.0068$ |
| gpm: gallons per minute | $(\text{gpm} \div \text{ID}^2) \times 0.4083$ |
| cfh: cubic feet per hour | $(\text{cfh} \div \text{ID}^2) \times 0.0509$ |
| cfm: cubic feet per minute | $(\text{cfm} \div \text{ID}^2) \times 3.0558$ |
| cfs: cubic feet per second | $(\text{cfs} \div \text{ID}^2) \times 183.35$ |

^aID = nominal hose size in inches

Example

Given:

3" nominal hose size
500 gallons per minute flow
Media is water
Hose is installed in 90° bend

Computation:

From the formula above,
 $(\text{gpm} \div \text{ID}^2) \times 0.4083$ or
 $(500 \div 9) \times 0.4083 = 22.68 \text{ ft./sec. flow velocity}$

Result:

Since the calculated flow velocity of 22.68 ft./sec. is less than 37 ft./sec., a liner is not required for this application.

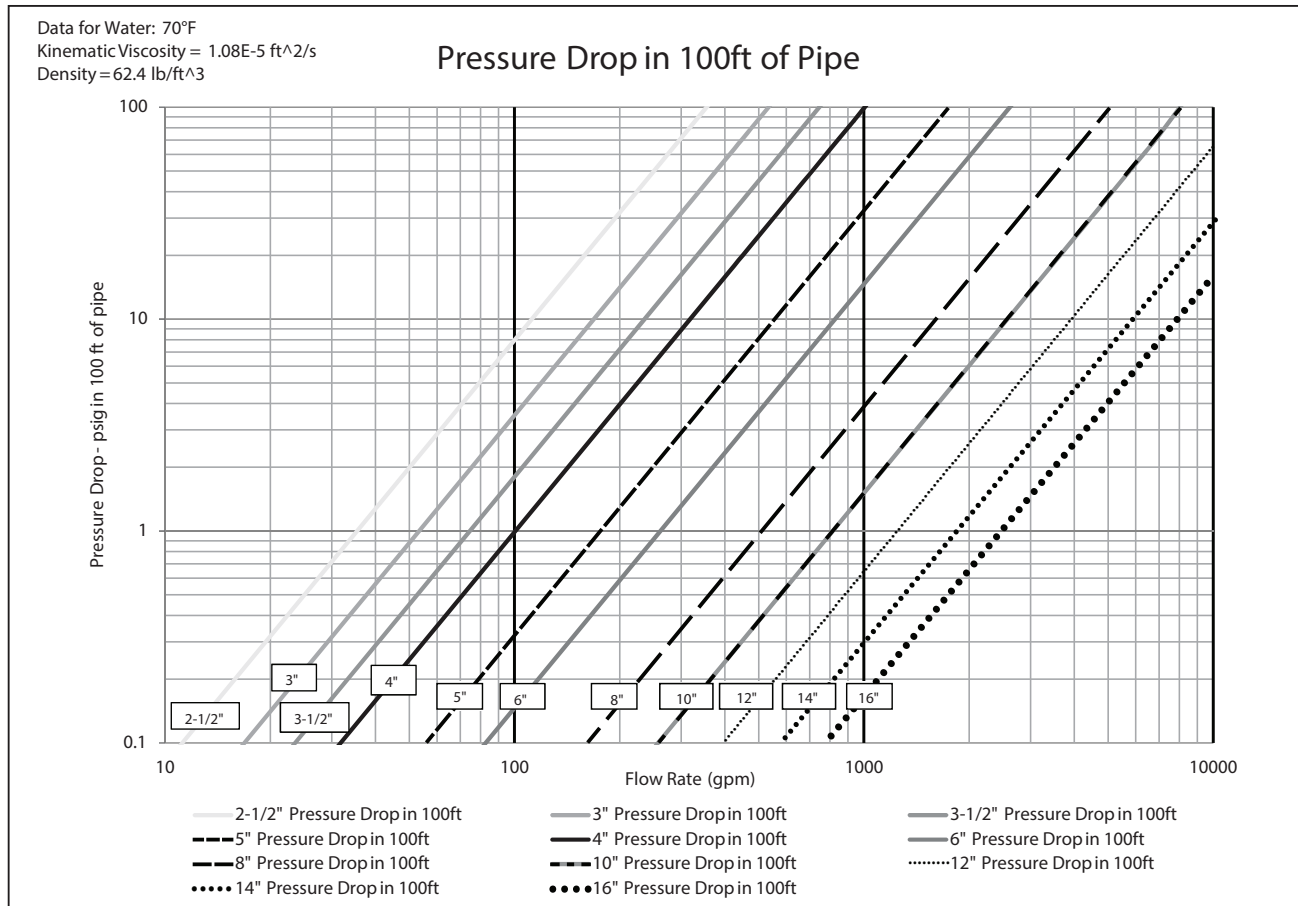
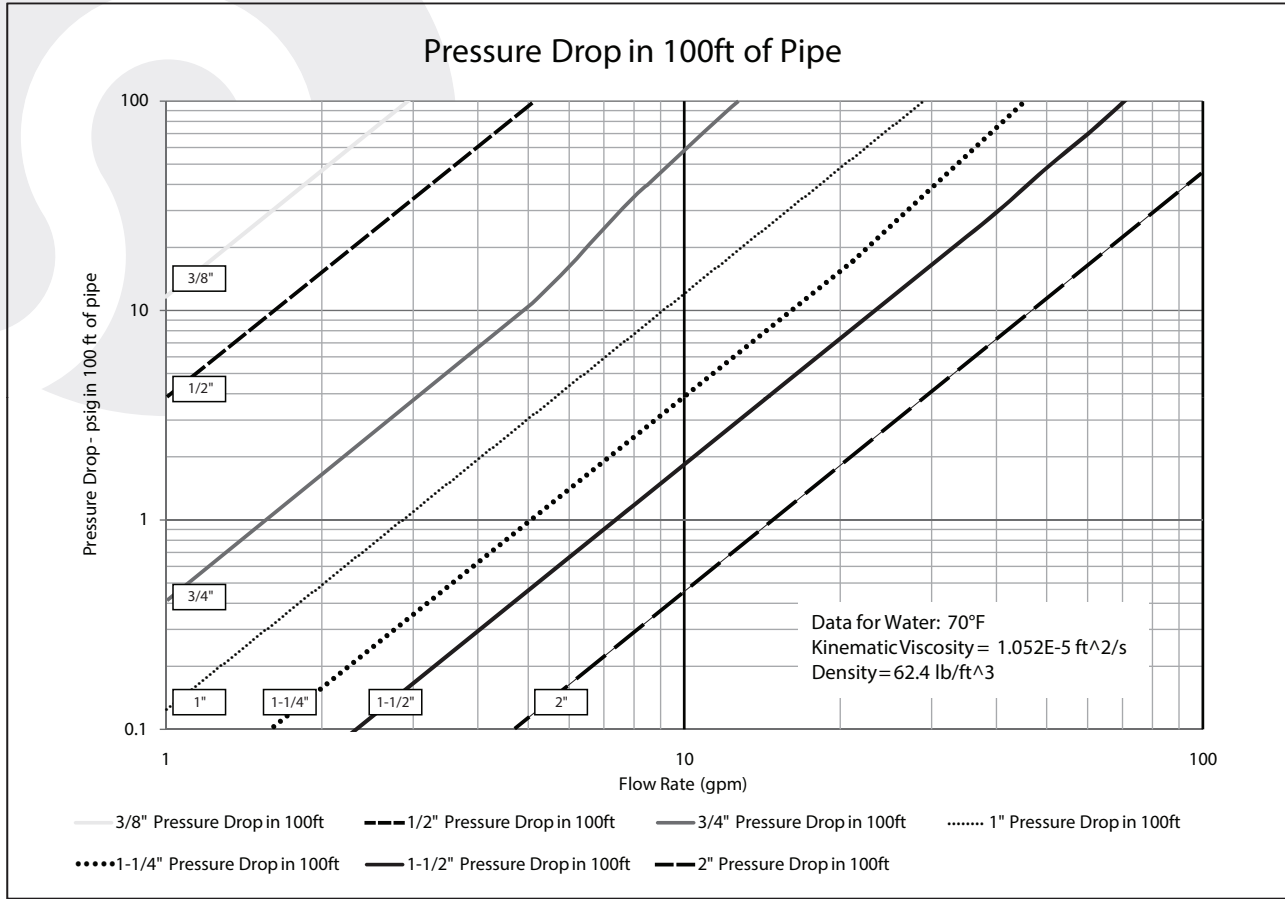

MEDIA

The metal hose assembly designer must know what the hose will convey. Matching the application piping material is sometimes used as a guide in selecting the alloy for the metal hose. However, this practice does not necessarily mean that the alloy selected is suitable. Metal hose is manufactured from thin wall material and may not have the same total life as heavier wall tube or pipe of the same material. Some factors to be considered when designing metal hose assemblies include corrosion, abrasion and viscosity of the media conveyed.

Corrosion

Material selection of the core and braid should take into consideration the corrosive nature of the media conveyed by the hose assembly and the outside environment. Corrosion can be accelerated by many chemicals when high temperature is present.

OmegaFlex does not publish corrosion resistance data because of the many variables present in metal hose applications. Many reference materials are available and provide accurate corrosion data. The Corrosion Data Survey published by the National Association of Corrosion Engineers (NACE) is considered to be one of the sources for corrosion resistance information.

Abrasion

For internal abrasion, premature failure can occur if the media is abrasive. The use of an interlock liner may extend the life of a hose assembly. For external abrasion, a protective cover may be used to extend hose life.

Viscosity

Flow of viscous media can be enhanced by incorporating the use of a jacketed hose assembly. This design utilizes an inner hose that is encapsulated by an outer hose.

TEMPERATURE

Operating Temperature

Core materials have unique temperature capabilities. Consult Temperature Correction Factor table for temperatures.

Excursion Temperatures

Surge or upset temperatures should be considered when selecting the proper materials.

TESTING

Standard testing of the weld and structural components of the hose assembly includes hydrostatic testing and pneumatic testing (utilizing either air or helium). Other testing methods used include mass spectrometer, cold shock and dye penetration. Contact OmegaFlex on other test procedures.

CLEANING

Special cleaning such as commercial oxygen, moisture reduction and others are available from OmegaFlex. Contact OmegaFlex with your specifications.

TEMPERATURE CORRECTION FACTORS

As the service temperature increases, the maximum pressure a hose assembly can withstand decreases. The material from which the hose is made and the method of fitting attachment (mechanical, soldered, welded, silver brazed) determine the maximum pressure at which an assembly can be used. By using the factors given in the chart below, the approximate safe working pressure at elevated temperatures can be calculated for assemblies with welded or mechanically attached fittings.

Temperature Correction Factors

| Temp | 304, 316L | 321 | | | | |
|------|-----------|-----------|--------|-------|-----------|---------|
| (°F) | Stainless | Stainless | Bronze | Monel | Hastelloy | Inconel |
| Room | 1.00 | 1.00 | 1.00 | 1.00 | 1.00 | 1.00 |
| 150 | .96 | .97 | .92 | .93 | .97 | .99 |
| 200 | .92 | .94 | .89 | .90 | .94 | .98 |
| 250 | .91 | .92 | .86 | .87 | .92 | .97 |
| 300 | .86 | .88 | .83 | .83 | .91 | .97 |
| 350 | .85 | .86 | .81 | .82 | .89 | .96 |
| 400 | .82 | .83 | .78 | .79 | .87 | .95 |
| 450 | .80 | .81 | .75 | .77 | .86 | .94 |
| 500 | .77 | .78 | — | .73 | .85 | .94 |
| 600 | .73 | .74 | — | .72 | .84 | .92 |
| 700 | .69 | .70 | — | .71 | .82 | .90 |
| 800 | .64 | .66 | — | .70 | .81 | .89 |
| 900 | — | .62 | — | — | .79 | .87 |
| 1000 | — | .60 | — | — | .78 | .86 |
| 1100 | — | .58 | — | — | .75 | .84 |
| 1200 | — | .55 | — | — | .73 | .82 |
| 1300 | — | .50 | — | — | .69 | .79 |
| 1400 | — | .44 | — | — | .65 | .77 |
| 1500 | — | .40 | — | — | — | .74 |

Saturated Steam Pressure To Temperature (PSIG)

| Saturated Steam (PSIG) | Temp (°F) | Saturated Steam (PSIG) | Temp (°F) | Saturated Steam (PSIG) | Temp (°F) |
|------------------------|-----------|------------------------|-----------|------------------------|-----------|
| 0 | 212 | 150 | 366 | 450 | 460 |
| 10 | 238 | 175 | 377 | 475 | 465 |
| 20 | 259 | 200 | 388 | 500 | 470 |
| 30 | 274 | 225 | 397 | 550 | 480 |
| 40 | 287 | 250 | 406 | 600 | 489 |
| 50 | 298 | 275 | 414 | 700 | 505 |
| 60 | 307 | 300 | 422 | 800 | 520 |
| 75 | 320 | 325 | 429 | 900 | 534 |
| 80 | 324 | 350 | 436 | 1000 | 546 |
| 90 | 331 | 375 | 442 | 1250 | 574 |
| 100 | 338 | 400 | 448 | 1500 | 606 |
| 125 | 353 | 425 | 454 | 2500 | 669 |

Example

How to determine if ¾" annular stainless hose with welded fittings is satisfactory for the given operating conditions:

Given:

Maximum operating temperature is 700° F.
Maximum operating pressure is 200 PSIG.

Computation:

From the specification table on page 5—nominal rated burst pressure for ¾" 312-SP0075 with welded fittings is 3200 PSIG.

From Temperature Correction Factors Chart—factor for stainless at 700°F is .70

Rated Burst Pressure: 3200 PSIG x .70 = 2240 PSIG (rated burst pressure at 700°F)

Safe Operating Pressure: 2240 ÷ 4 = 560 PSIG (using 4:1 safety factor)

Result:



Since the maximum operating pressure for 312-SP0075 at 700°F is 560 PSIG the hose will meet the required operating conditions outlined above.

Saturated Steam Pressure To Temperature (Hg)

| Saturated Steam Vacuum (in. of Hg) | Temp (°F) |
|------------------------------------|-----------|
| — | 0 |
| 29.84 | 20 |
| 29.74 | 32 |
| 29.67 | 40 |
| 29.39 | 60 |
| 28.89 | 80 |
| 27.99 | 100 |
| 26.48 | 120 |
| 24.04 | 140 |
| 20.27 | 160 |
| 15.20 | 180 |
| 6.46 | 200 |

FITTINGS

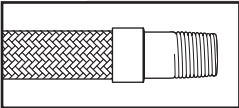
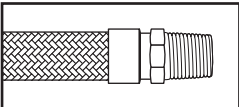
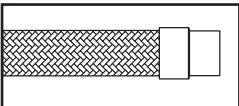
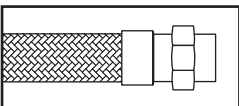
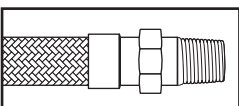
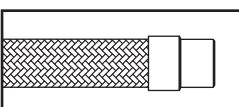
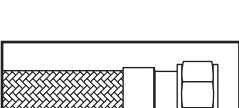
Many different fitting designs may be attached to the hose assembly. Selection of the proper material for the end fittings must be considered. Fitting materials such as carbon steel, malleable iron, stainless steel, bronze or brass may or may not be the same as the hose assembly material. Correct attachment of the fittings is essential to the integrity of the assembly. Contact OmegaFlex if the attachment of dissimilar metals is required.

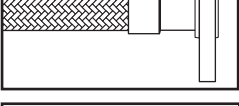
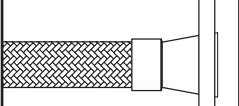
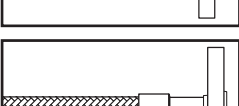
| Fitting | Description |
|---|---|
|  Male Pipe (Solid) | Pipe thread — Sch 40 Std Weight Sch 80 Heavy Weight |
|  Hex Male Pipe (Solid) | Pipe thread — with integral or attached hex |
|  Female Pipe (Solid) | Female pipe thread — also may be supplied with hex |
|  Female Union | Female pipe thread with ground joint union as specified |
|  Male Union | Male pipe thread with ground joint union as specified |
|  Weld-Plain Pipe End (Solid) | Pipe tube end specified by Sch 40 or Heavy Weight Sch 80 |
|  Tube End (Solid) | Plain tube end specified by O.D. and wall thickness |
|  Tube with Fittings (Swivel) | Tube flared with sleeve and nut for female JIC/SAE swivel fitting, as specified. Overall length is normally measured seat to seat. |
|  Flange (Fixed) | a) Forged steel — per ASTM specification from 125 lb. to 600 lb. b) Plate steel — where permissible cut and drilled to 150 lb. or 300 lb. dimensions |
|  Flange-Weldneck (Fixed) | Forged steel — per ASTM specification from 125 lb. to 600 lb. |
|  Flange-Lap Joint (Floating) | a) Lap joint forges flange per ASTM specification from 125 lb. to 600 lb., must be used with MSS/ANSI "A" forged stub end Std or Extra Heavy b) Slip-on or plate flange for lighter weight schedule 10 stub ends |

INSTALLATION PRECAUTIONS

DO NOT COMPRESS OR EXTEND AXIALLY.

Corrugated metal hose installed in-line with the longitudinal axis of the piping should not be subjected to axial movement.

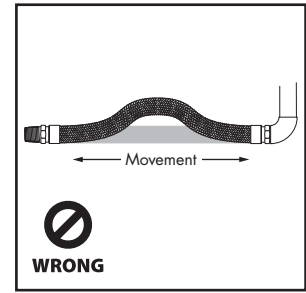
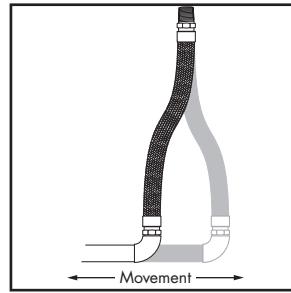

DO NOT TORQUE DURING INSTALLATION.

Metal hose assemblies should not be used to compensate for bolt hole misalignment. Floating flanges will help to minimize twisting of the metal hose. Pipe unions will help to reduce twisting during connection to the piping. The use of two wrenches will help to keep the hose from twisting when tightening the pipe union.

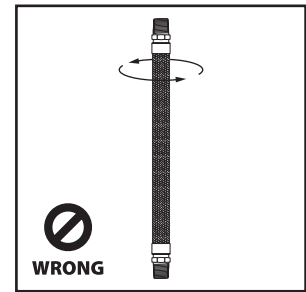
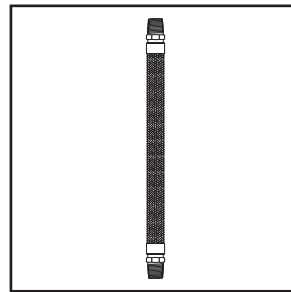

DO NOT ALLOW HOSE MOVEMENT IN MULTIPLE PLANES.

Flexing a metal hose in two separate planes of movement will torque the hose assembly. Always install the metal hose assembly so that flexing occurs in one plane only and this is the same plane in which bending occurs.

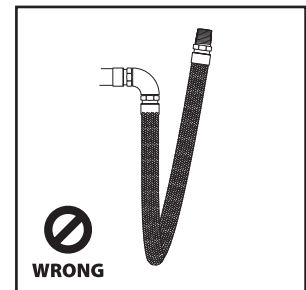
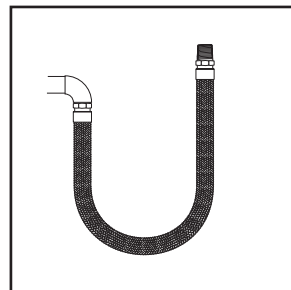

AVOID SHARP BENDS.

Use elbows to avoid severe bends near the end of the metal hose assembly.

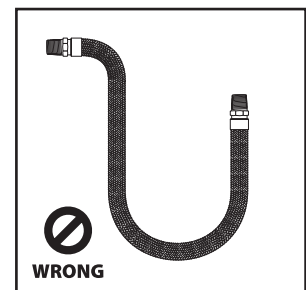
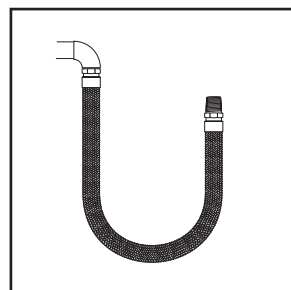

MAINTAIN MINIMUM CENTERLINE BEND RADIUS.

The minimum centerline bend radius for dynamic flexing should never be less than the values in the product specification tables.

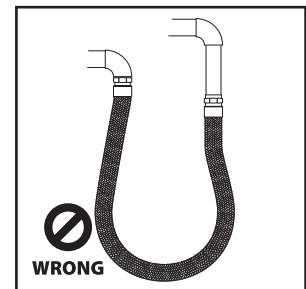
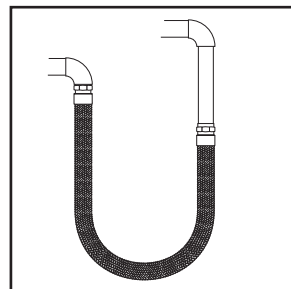

SERVICE LIFE FACTORS

The following describes various service life factors in corrugated metal hose applications. The information is based on our experience as a manufacturer of metal hose, braid products and metal hose assemblies. While this information is intended to be a general guide, each application should be evaluated individually because of the many variables that affects service life of metal hose assemblies.

General Corrosion

Uniform attack through the entire corrugated length of the metal hose assembly is mostly described as general corrosion. Attack on the alloy is affected by chemical concentration, temperature and the type of alloy from which the metal hose is manufactured. Some typical areas of attack include the root or bottom of the corrugation and in the heat affected weld area.

Most stainless alloys form a protective film of stable oxides on the surface when exposed to oxygen gas. The rate of oxidation is dependent on temperature. At normal temperatures, a thin film of oxide is formed on the alloy surface. Higher temperatures will cause oxidation to proceed more rapidly.

The oxides that form on copper or nickel alloys are of a nonporous oxide formation. A nonporous oxide formation will provide a protective layer on the surface but if the layer is removed, no protection is provided to the underlying metal.

Factors when selecting piping and corrugated metal hose assembly materials should consider that the piping is a rigid member and the hose assembly will be subject to flexing. As outlined later in the Service Life Factors section, several factors associated with flexing affect the service life of a metal hose.

Service life may be affected by factors external to the metal hose assembly. Consideration should be give to the chemical composition of the environment surrounding the hose assembly as well as the media being transferred when selecting an alloy.

OmegaFlex does not publish corrosion resistance data because of the many variables present in metal hose applications. Many reference materials are available and provide accurate corrosion data. The Corrosion Data Survey published by the National Association of Corrosion Engineers (NACE) is one of many sources of reference for corrosion resistance information.

High Velocity/Chemical Abrasives

Turbulent flow of abrasive chemical media over the alloy surface may cause accelerated corrosion or erosion-corrosion. Liquids or gases that have suspended solid particles will wear or remove the oxide protective film and leave the alloy exposed and more susceptible to corrosion. Some forms of flow assisted corrosion include terms such as cavitation or impingement. Reducing the velocity or incorporating a liner in the metal hose assembly may reduce the effects of this type of abrasion.

High Cycle/Chemical Media

Applied stresses such as flexing or cyclic motion may reduce the oxide film surface effectiveness against corrosion. Cracks, resulting from cycling of the hose assembly, form in the protective oxide layer on the surface of the alloy thus reducing the effectiveness against corrosion. The introduction of a corrosive environment often eliminates the fatigue limit of the alloy creating a finite life regardless of stress level.

Stress Corrosion

The detailed mechanism of stress corrosion is complicated and not well understood. The process of stress corrosion seems to be one of initial formation of corrosion pits and crevices, and subsequent fracture due to stress concentrations associated with the crevices. Stress corrosion cracks often follow crystal boundaries in the grain structure of the alloy. Visual examination of high cycle/chemical media and stress corrosion failures appears similar. Application data specifying media, temperature and movements is very useful in order to determine the exact cause for failure.

Chlorides and caustics are the media most frequently found to cause stress corrosion cracking. Relieving stresses or selection of an alloy know for resistance to the conveyed media are possible ways to reduce this type of failure.

SERVICE LIFE FACTORS (Continued)

Intergranular Corrosion/Attack

Corrosion along the grain boundaries of the metal may occur and the grains of metal separate from the mass causing loss of strength and ductility. Failure due to loss of ductility is also known as brittle fracture. Alloys such as 304L or 316L have been developed to reduce the effects of intergranular corrosion. These low carbon alloys have a grain structure that is more resistant to corrosion.

Intergranular attack may occur when certain grades of stainless steel such as 304 or 316 are subjected to temperatures beyond 800°F. Chromium can precipitate out of solution, bonding with carbon and forming chromium carbides on grain boundaries at this temperature and above. Reduced protection from the loss of chromium when combined with corrosive media leaves the grain structure exposed to possible corrosive attack.

Using a stabilized grade of stainless steel, such as T321, is an effective method for preventing sensitization. Stabilized alloys sacrifice the stabilizing element to the carbon thus preventing loss of chromium in the grain structure.

Pitting Corrosion

Highly localized attack with the appearance of a relatively sharp or well-defined boundary and a surrounding area that appears unattacked is referred to as pitting corrosion. Pitting may occur in crevices, inclusions, imbedded iron or other metals, also items such as marine organisms in sea water adhering to metal surfaces or grease.

Fatigue

Progressive damage due to the flexing of the corrugations is known as fatigue. Stress generated by flexure, pulsation, torsion, vibration and flow induced vibration are some causes for fatigue failure. Continual small cracks form in the metal. Fatigue cracks often originate at small imperfections, such as non-metallic inclusions, within the metal. Stress will concentrate at the crack and further cycling will increase the size of the crack until a complete fracture occurs. Fatigue damage normally occurs as a circumferential crack at the top or bottom of the corrugation.

Additionally, high flow velocity may cause the corrugations to vibrate at a high frequency and resonance vibration may occur. See High Flow Velocity below. Increasing the bend radius will decrease the stress level in the individual corrugations. Changes in corrugation count of the hose or control of the motion may also increase hose life.

High Flow Velocity

Applications where the flow of a liquid or gas is above manufacturer recommended levels and a liner is not incorporated into the hose assembly design often results in premature fatigue failure. The high flow velocity causes the corrugations to vibrate at a high frequency and, if the vibration is near the natural frequency of the hose, failure will occur very quickly.

Spider web type cracks and fractured pieces of metal breaking from the corrugations are typical appearances for this type of failure. Reducing the velocity by increasing the hose diameter or the use of an interlocked type liner are possible ways to avoid high flow velocity failures.

Torsion

Rotation about the longitudinal axis develops a shear stress in the metal that can cause premature damage. Twisting the metal hose assembly during installation or as a result of movement in two planes can produce cracks that start circumferentially on the crown or outside of more than one corrugation and progress longitudinally. Torsion is one of the most common causes for premature metal hose failure. Incorporating a lay line on the metal hose assembly will provide means for determining if the hose is rotating about the longitudinal axis.

Vibration

Vibration damage starts as very small or irregular cracks, primarily close to the vibration source, around the circumference of the corrugation. The cracks may progress to the corrugation wall in the form of a "Y." Extreme braid wear on the crown or top of the corrugation is usually present. If the vibration is near the natural frequency of the hose, failure will occur very quickly. Corrugated metal hose may be harmonically tuned to compensate for damaging frequencies.

Low Pressure Applications

Caution must be used when unbraided metal hose assemblies are used in low-pressure applications such as engine exhaust. Proper installation practices, as outlined by the Expansion Joint Manufacturers Association (EJMA), utilizing piping guides and anchors must be observed to prevent premature damage of the metal hose assembly. The addition of braid should be considered for vibration attenuation.

CORRUGATED METAL HOSE (DESIGNING AN ASSEMBLY)

ANALYZING AN APPLICATION

S.T.A.M.P.E.D.

To properly design a metal hose assembly for a particular application, the following design parameters must be determined. To help remember them, they have been arranged to form the acronym "S.T.A.M.P.E.D."

1. **S**ize - The diameter of the connections in which the assembly will be installed is needed to provide a proper fit. This information is required.
2. **T**emperature - As the temperature to which the assembly is exposed (internally and externally) increases, the strength of the assembly's components decreases. Also, the coldest temperature to which the hose will be exposed can affect the assembly procedure and/or fitting materials. If you do not provide this information it will be assumed that the temperatures are 70°F.
3. **A**pplication - This refers to the configuration in which the assembly is installed. This includes both the dimensions of the assembly as well as the details of any movement that the assembly will experience. This information is necessary to calculate assembly length and required flexibility.
4. **M**edia - Identify all chemicals to which the assembly will be exposed, both internally and externally. This is important since you must be sure that the assembly's components are chemically compatible with the media going through the hose as well as the environment in which the hose is installed. If no media is given, it will be assumed that both the media and the external environment are compatible with all of the available materials for each component.
5. **P**ressure - Identify the internal pressure to which the assembly will be exposed. Also, determine if the pressure is constant or if there are cycles or spikes. This information is important to determine if the assembly is strong enough for the application. If no pressure is given it will be assumed that the pressure is low and there are no pressure surges or spikes.
6. **E**nd Fittings - Identify the necessary end fittings. This is required since fittings for the assembly must be chosen to properly fit the mating connections.
7. **D**ynamics - Identify the velocity at which the media will flow through the assembly. Since corrugated metal hose does not have a smooth interior, rapid media flow can set up a resonant frequency that will cause the hose to vibrate and prematurely fail. If no velocity is given, it will be assumed that the velocity is not fast enough to affect the assembly's performance.

HOSE APPLICATION SPECIFIER

Date _____

Company _____ Contact _____

Address _____

Phone _____ Fax _____ Email _____

SIZE

I.D. _____ O.D. _____ Overall Length _____

TEMPERATURE

Operating _____ °F Design _____ °F Excursion _____ °F External _____ °F

APPLICATION

Motion: Lateral One Side of Centerline _____ Other Side of Centerline _____

Angular One Side of Centerline _____ Other Side of Centerline _____

Motion Frequency _____ Cycles per _____

Assembly Configuration: Hose Straight Dogleg Jacketed/Duplex Vertical Loop Horizontal Loop

Define Dogleg Lengths _____

Liner Required Yes No Liner Material _____Cover Required Yes No Cover Material _____

Assembly Drawing

MEDIA

Internal Flow Media _____

External Environment Corrosives _____

Hose Material _____ Braid Material _____

Braid Layers 0 1 2**PRESSURE**

Working Pressure _____ psig Test Pressure _____ psig Vacuum _____ Hg

Pressure Type Constant Shock Pulsating Intermittent

Define shock or pulsating pressure _____

External Pressure _____ psig Atmospheric**END FITTINGS**

Fitting #1: Size Type Material _____

Fitting #2: Size Type Material _____

Pipe schedule, wall thickness or pressure rating _____

DYNAMICS

Velocity: _____ Ft./Sec.

Omega Flex, Inc.,
451 Creamery Way, Exton, PA 19341-2509 Tel:1-610-524-7272 FAX:1-610-524-6484 www.omegaflex.com

Call 1-800-355-1039

LIMITED WARRANTY

Omega Flex, Inc. (the "Manufacturer") warrants that all OmegaFlex Industrial Division corrugated metal hose, braid, corrugated metal hose assemblies, vibration absorbers or expansion joints (the "Product") will be free from defects in material or workmanship for one year from the date of shipment. If upon examination by the Manufacturer, the Product is shown to have a defect in material or workmanship during the warranty period, the Manufacturer will repair or replace, at its option, that part of the Product which is shown to be defective.

This limited warranty does not apply:

- if the Product has been subjected to misuse or neglect, has been accidentally or intentionally damaged, or has been altered or modified in any way.
- to any expenses, including labor or material, incurred during investigation, removal or reinstallation of the defective Product or parts thereof.
- to any damage or impairment of the Product caused by any casualty, including without limitation fire, wind, floods, or acts of God.
- to any workmanship of the fabricator (if other than OmegaFlex) or installer of the Product.

This limited warranty is conditional upon:

- shipment, to the Manufacturer, of that part of the Product thought to be defective. Goods can only be returned with prior written approval from the Manufacturer. All returns must be freight prepaid.
- determination, in the reasonable opinion of the Manufacturer, that there exists a defect in material or workmanship.

Repair or replacement of any part under this Limited Warranty shall not extend the duration of the warranty with respect to such repaired or replaced part beyond the stated warranty period.

THIS LIMITED WARRANTY IS IN LIEU OF ALL OTHER WARRANTIES, EITHER EXPRESS OR IMPLIED, AND ALL SUCH OTHER WARRANTIES, INCLUDING WITHOUT LIMITATION IMPLIED WARRANTIES OF MERCHANTABILITY OR FITNESS FOR A PARTICULAR PURPOSE, ARE HEREBY DISCLAIMED AND EXCLUDED FROM THIS LIMITED WARRANTY.

IN NO EVENT SHALL THE MANUFACTURER BE LIABLE IN ANY WAY FOR ANY CONSEQUENTIAL, SPECIAL, OR INCIDENTAL DAMAGES OF ANY NATURE WHATSOEVER, OR FOR ANY AMOUNTS IN EXCESS OF THE SELLING PRICE OF THE PRODUCT OR ANY PARTS THEREOF FOUND TO BE DEFECTIVE. THIS LIMITED WARRANTY GIVES THE ORIGINAL OWNER OF THE PRODUCT SPECIFIC LEGAL RIGHTS. YOU MAY ALSO HAVE OTHER RIGHTS WHICH MAY VARY BY EACH JURISDICTION.

DISCLAIMER

The products illustrated reflect the design characteristics at time of printing. Please contact the factory for certified prints with exact dimensions when required.

This catalog is provided to assist the user in selection and application of OmegaFlex flexible metal hose and braid. The technical data contained herein is a guide to the user of OmegaFlex products. The data contained herein is based upon tests and information believed to be reliable, but users should not rely upon it absolutely for specific applications. It is given and accepted at user's risk and confirmation of its validity and suitability in particular cases should be obtained independently.

OmegaFlex makes no guarantee of results and assumes no obligation or liability in connection with this data. This publication is not to be taken as a license to operate under or recommendation to infringe any patents.

OmegaFlex policy is one of continuous improvement and development. OmegaFlex reserves the right to change specifications and introduce improved designs without notice.



Omega Flex, Inc.
451 Creamery Way
Exton, PA 19341-2509
800-355-1039
Tel: 610-524-7272
Fax: 610-524-6484
www.omegaflex.com

