

# CHLORINE Hose Assembly

## Chlorine Hose Assembly With Monel Stub Ends And Carbon Steel Flanges:

Item	Description	Material
1.	300# Lap Joint Flange	Carbon Steel
2.	Schedule 80 Type A Stub End	Monel 400
3.	Collars	Monel 400
4.	Chafe Guard	304L Stainless Steel
5.	1 or 2 Braid Layers	Monel 400
6.	Corrugated Tube	Monel 400

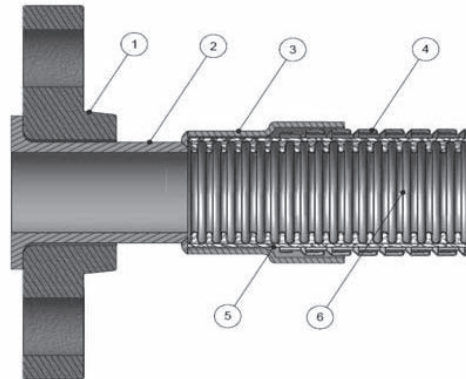

## Specifications — Pressure ratings at 70°F (PSIG)

Size (NON)	Corrugated Tubing ID (NOM)	Casing OD (in.) 1B / 2B	Max Working Pressure 1B / 2B	Max Test Pressure 1B / 2B	Nominal Burst 1B / 2B
½	0.550	1.000 1.130	681 1,077	1,362 2,154	3,406 5,385
¾	0.800	1.260 1.380	567 929	1,134 1,858	2,835 4,643
1	1.025	1.650 1.780	554 907	1,108 1,814	2,769 4,533
1¼	1.242	2.030 2.160	489 792	978 1,584	2,445 3,962
1½	1.563	— 2.530	— 615	— 1,230	— 3,075
2	1.992	— 3.030	— 493	— 986	— 2,463

## Chlorine Institute Pamphlet 6 Hose Assembly

- Hydrostatic tested at 2 times the MAWP
- Commercial oven dried to ensure moisture is removed
- Weld inspection with Helium Mass Spectrometer at a leak rate of  $1 \times 10^{-9}$
- Yearly samples tested at 5 times the MAWP and 2 times 15% deformation
- Manufactured to ISO 10380 bending requirements
- Procedures and Welder Qualifications in accordance with ANSI/ASME BPV-IX AND ASME B31.3
- Packaged, tagged, and all documentation per specification
- Material verified using a calibrated handheld X-ray Fluorescence Analyzer (PMI)