

CHLORINE HOSE ASSEMBLY SPECIFICATION DATA SHEET

DESCRIPTION

The OmegaFlex® Chlorine Hose Assembly consists of corrugated Monel 400 alloy tubing with Monel 400 one or two layers of braid. End fittings are either schedule 80 Monel NPT or Type A carbon steel Lap Joint flanges with Monel stub ends. 304 stainless steel casing covers the outside of the assembly. The hose assemblies are manufactured in accordance with the Chlorine Institute pamphlet 6 current addition.

CHLORINE HOSE ASSEMBLY MATERIALS

TUBING MATERIAL: Corrugated Monel 400 tubing conforms to ASTM B-127, Monel alloy UNS No. N04400.

BRAID MATERIAL: Monel 400 wire conforms to QQ-N-281 Rev D. Monel alloy UNS No. N04400.

FITTING MATERIAL: Monel 400 schedule 80 pipe conforms to ASTM B-165, Monel alloy UNS No. N04400 or ASTM A-105, ANSI B16.5 Class 300 Carbon Steel Lap Joint Flanges with Monel 400 stub ends conforming to ASTM B-366

CASING MATERIAL: 304L Stainless steel conforms to ASTM A-240, 304L alloy UNS No. S30403

RESOURCES: The Chlorine Institute Pamphlet 6 – Piping for Dry Chlorine
 ISO 10380:2012 Pipework – Corrugated Metal Hoses and Hose Assemblies
 NAHAD 400:2005 – Corrugated Metal Hose Assembly Specification Guidelines

OPERATIONAL TEMPERATURES: -40°F to 122°F

CHLORINE HOSE ASSEMBLY WITH SCHEDULE 80 NPT END FITTINGS:

Item	Description	Material
1.	Schedule 80 Pipe NPT	Monel 400
2.	Wrench Nut	Carbon Steel
3.	Collars	Monel 400
4.	Chafe Guard	304L Stainless Steel
5.	1 or 2 Braid Layers	Monel 400
6.	Corrugated Tube	Monel 400

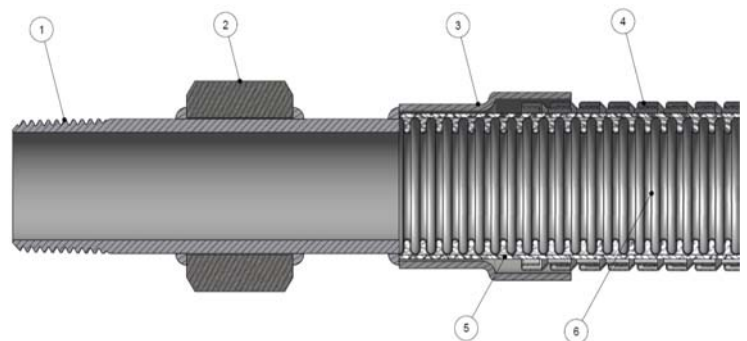

CHLORINE HOSE ASSEMBLY WITH MONEL STUB ENDS AND CARBON STEEL FLANGES:

Item	Description	Material
1.	300# Lap Joint Flange	Carbon Steel
2.	Schedule 80 Type A Stub End	Monel 400
3.	Collars	Monel 400
4.	Chafe Guard	304L Stainless Steel
5.	1 or 2 Braid layers	Monel 400
6.	Corrugated Tube	Monel 400

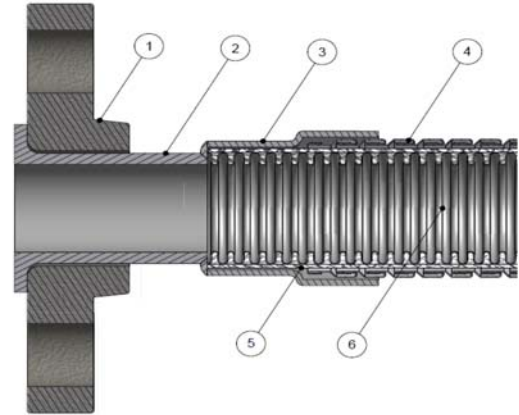

SPECIFICATIONS: Pressure ratings at 70°F (PSIG)

Size (nom)	1/2"	3/4"	1"	1-1/4"	1-1/2"	2"
Corrugated Tubing ID (in.)	0.550	0.800	1.025	1.242	1.563	1.992
Casing OD (in.)	1.000	1.260	1.650	2.030	—	—
1B / 2B	1.130	1.380	1.780	2.160	2.530	3.030
Max Working Pressure	681	567	554	489	—	—
1B / 2B	1,077	929	907	792	615	493
Max Test Pressure	1,362	1,134	1,108	978	—	—
1B / 2B	2,154	1,858	1,814	1,584	1,230	986
Nominal Burst	3,406	2,835	2,769	2,445	—	—
1B / 2B	5,385	4,643	4,533	3,962	3,075	2,463

CHLORINE INSTITUTE PAMPHLET 6 HOSE ASSEMBLY SPECIFICATIONS:

- Hydrostatic tested at 2 times the MAWP
- Commercial oven dried to ensure moisture is removed
- Weld inspection with Helium Mass Spectrometer at a leak rate of 1×10^{-9}
- Yearly samples tested at 5 times the MAWP and 2 times 15% deformation
- Manufactured to ISO 10380 bending requirements
- Procedures and Welder Qualifications in accordance with ANSI/ASME BPV-IX AND ASME B31.3
- Packaged, tagged, and all documentation per specification
- Material verified using a calibrated handheld X-ray Fluorescence Analyzer (PMI)